

**Huck®**

Lockbolts,  
Structural Blind  
Rivets, and Tooling



## Durable Locking Performance in High Vibration Environments

It's the proven reliable, vibration-resistant locking performance that has made The Huck® brand famous.

You'll find it in every HuckBolt®. Delivering uniform, consistent clamp load and high shear and tensile strength, HuckBolts are ideal for applications ranging from general manufacturing to high-vibration environments such as HVAC, trailer and container assembly, rotating equipment, shopping carts, railroad and transit cars, geodesic structures, and many others.

HuckBolts feature an exclusive locking groove design that ensures a tight, permanent fit. In addition to superior fastening performance regardless of which lockbolt type you require, HuckBolts have been proven to reduce labor and installation costs, along with rework and warranty expenses. Stronger, easier to install, and more durable than welding, adhesives, or conventional threaded fastening systems, HuckBolts have been the professionals' choice for decades.

### HuckBolt Tooling

Model SFBTT20  
SWAGEFORWARD®



Lightweight and technologically advanced, HuckBolt tooling makes the installation process quick and easy. For instance, this tool represents our most advanced installation tool yet.

### Table of Contents

HuckBolts	2
BobTail®	4
C50L®	9
C6L®	13
Magna-Grip®	18
Hucktainer®	22
Huck 360®	26
Huck Structural Blind Rivets	28
Magna-Lok®	30
HuckLok®	37
Auto-Bulb™	40
Magna-Tite®	42
BOM®	44
FloorTight®	47
Huck Tools	49

## Types



### BobTail®

Huck's swaged-on fastener with no break-off pintail. Corrosion resistant and installs with lightweight ergonomic tooling.



### C50L®

Superior vibration resistance and durability for heavy-duty applications. Meets or exceeds all ASTM A-325 standards for shear, tensile and fatigue life.

### C6L®/C120L/C150L

The classic 6-groove locking fastener ideal for a wide range of applications. Available in grades, 2, 5, and 8.



### Magna-Grip®

Vibration-resistant, reliable grade 2 fasteners offering high uniform installed values with a wide grip range.



### Hucktainer®

Panel fastener that installs with consistent pressure, reducing crushing or crazing.



### Huck 360®

The engineered nut-and-bolt fastening system with a unique, embedded thread design for superior vibration resistance.

Contact Arconic Fastening Systems and Rings for availability



# BobTail®

Huck's next-generation, pintail-less HuckBolt.

Representing the most advanced fastening technology to date, the BobTail® has been developed to deliver the highest level of performance and reliability.

Engineered to meet the challenges of a wide range of assembly applications, BobTail offers safe, quiet, swage-on installation technology in a unique, pintail-less design. Available in both Grade 5 and Grade 8 and in an assortment of sizes, BobTail offers 5 times the fatigue strength of conventional nuts and bolts, and unmatched installation speed – often under 2 seconds per fastener.

Its unique no-break-off pintail offers the highest corrosion-resistance in its class, while advanced, low-swage technology enables installation with lightweight, ergonomic tools. When you factor in the cost of fasteners with installation and inspection labor, BobTail often provides an overall lower installed cost.

**Available Sizes:**

3/16", 1/4", 5/16", 3/8", 1/2", 5/8", 3/4", 7/8", 1"  
12mm, 14mm, 16mm, 20mm

**Materials:**

Steel, Aluminum, Stainless Steel

**Headstyles:**

Round, Truss, 90° Flush, Flanged, 98T



## Swage indicators allow easy visual inspection

1. Pintail-less design means reduced noise, no waste, and improved corrosion resistance.
2. Visual evidence of successful installation provided by installation indicator.
3. Collar material swaged into the lockgrooves forms a permanent, vibration-resistant connection.
4. Low-swage technology allows for faster, lighter, ergonomic tooling with parts that last longer.

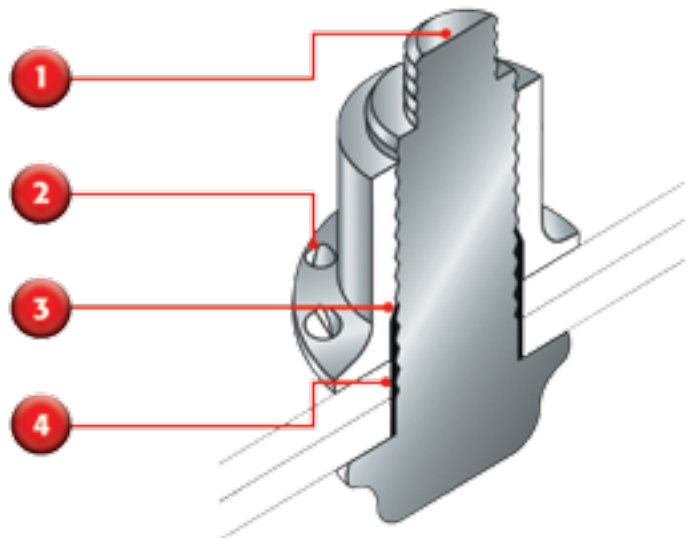



## Installation Sequence

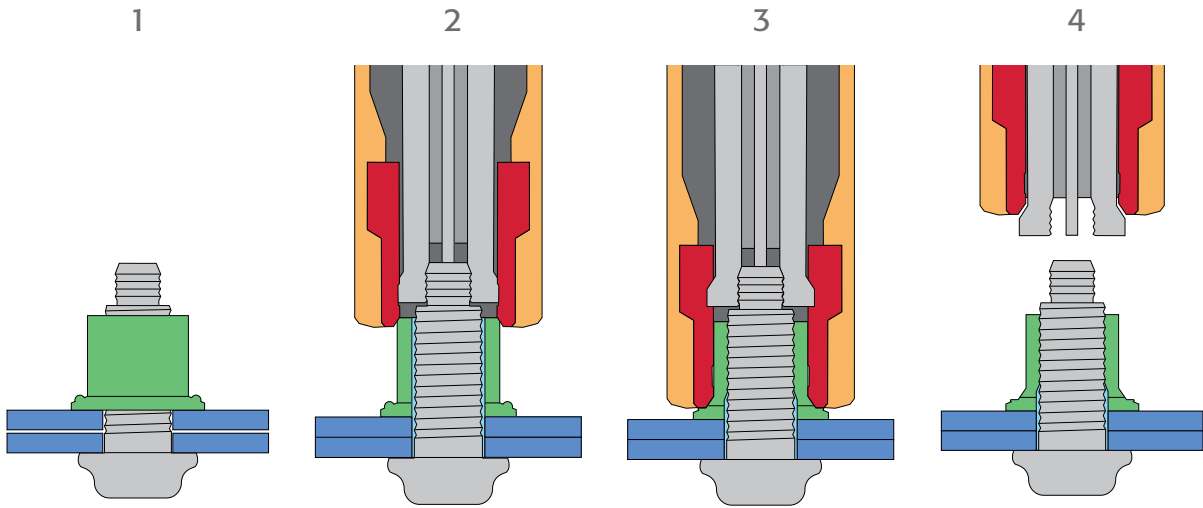

1  
The pin is inserted into the prepared hole, and the collar is spun onto the pin.

2  
The installation tool is applied to annular pull grooves. When the tool is activated, a puller in the nose assembly draws the pin into the tool, causing the swaging anvil to press on the collar, drawing up any sheet gap.

3  
At a predetermined force, the anvil begins to swage the collar into the pin's lockgrooves. Continued swaging elongates the collar and pin, developing precise clamp.

4  
When swaging of the collar into the pin lockgrooves is complete, the tool ejects the fastener and releases the puller to complete the sequence.



## Small Diameter BobTail Data and Dimensions

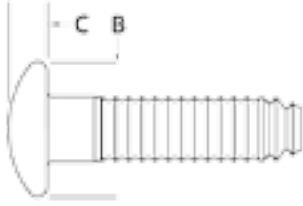

### Steel

Diameter	Part No.	Grip Range	Max Hole Size	[B] Head Dia (max)	[C] Head Height (max)	Typical Shear (lbs)	Typical Clamp (lbf)	Typical Tensile (lbs)
<b>98 Degree Head</b>								
1/4"	BT98T-R8-2GA	0-.250	.281	.595	.155	3050	1805	3000
	BT98T-R8-3GA	.063-.312	.281	.595	.155	3050	1805	3000
	BT98T-R8-4GA	.125-.375	.281	.595	.155	3050	1805	3000
	BT98T-R8-5GA	.187-1.000	.281	.595	.155	3050	1805	3000
	BT98T-R8-6GA	.250-1.063	.281	.595	.155	3050	1805	3000
	BT98T-R8-7GA	.312-.562	.281	.595	.155	3050	1805	3000
	BT98T-R8-8GA	.375-.625	.281	.595	.155	3050	1805	3000
	BT98T-R8-10GA	.500-.750	.281	.595	.155	3050	1805	3000
	BT98T-R8-12GA	.625-.875	.281	.595	.155	3050	1805	3000
3/8"	BT98T-R12-4GA	.125-.375	.422	.820	.240	6825	4020	6500
	BT98T-R12-6GA	.250-.500	.422	.820	.240	6825	4020	6500
	BT98T-R12-8GA	.375-.625	.422	.820	.240	6825	4020	6500
	BT98T-R12-10GA	.500-.750	.422	.820	.240	6825	4020	6500
	BT98T-R12-12GA	.625-.875	.422	.820	.240	6825	4020	6500
	BT98T-R12-14GA	.750-1.000	.422	.820	.240	6825	4020	6500
	BT98T-R12-16GA	.875-1.125	.422	.820	.240	6825	4020	6500
BT98T-R12-18GA	1.000-1.250	.422	.820	.240	6825	4020	6500	

### Stainless Steel

Diameter	Part No.	Grip Range	Max Hole Size	[B] Head Dia (max)	[C] Head Height (max)	Typical Shear (lbs)	Typical Clamp (lbf)	Typical Tensile (lbs)
<b>400 Series Stainless Polished Heads</b>								
1/4"	BT98T-4U8-2BR	0-.250	.281	.595	.155	3550	1805	2750
	BT98T-4U8-3BR	.063-.312	.281	.595	.155	3550	1805	2750
	BT98T-4U8-4BR	.125-.375	.281	.595	.155	3550	1805	2750
	BT98T-4U8-5BR	.187-1.000	.281	.595	.155	3550	1805	2750
	BT98T-4U8-6BR	.250-1.063	.281	.595	.155	3550	1805	2750
	BT98T-4U8-8BR	.375-.625	.281	.595	.155	3550	1805	2750
	BT98T-4U8-10BR	.500-.750	.281	.595	.155	3550	1805	2750
	BT98T-4U8-12BR	.625-.875	.281	.595	.155	3550	1805	2750
3/8"	BT98T-4U12-6BR	.250-.500	.422	.820	.240	7950	4020	6100
	BT98T-4U12-8BR	.375-.625	.422	.820	.240	7950	4020	6100
	BT98T-4U12-10BR	.500-.750	.422	.820	.240	7950	4020	6100
	BT98T-4U12-12BR	.625-.875	.422	.820	.240	7950	4020	6100
	BT98T-4U12-14BR	.750-1.000	.422	.820	.240	7950	4020	6100
	BT98T-4U12-16BR	.875-1.125	.422	.820	.240	7950	4020	6100
	BT98T-4U12-20BR	1.125-1.375	.422	.820	.240	7950	4020	6100

NOTE: Part number listings reflect typical stock. Items not listed will require a minimum order.

## Large and Small Diameter BobTail Collars

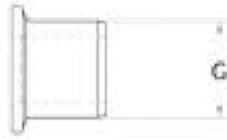

### Steel

Diameter	Part No.	Width (G)
1/4"	BTC-R8GAHL	.396
3/8"	BTC-R12GAHL	.599

### 430 Stainless Steel

Diameter	Part No.	Width (G)
1/4" with tab	BTC-R8GAHL	.396
3/8" with tab	BTC-R12GAHL	.599

### Steel, Zinc Plated

Diameter	Part No.	Width (G)
16MM	MBTC-R16BL	24.1-24.5mm
20MM	MBTC-R20BL	30.2-30.6mm
5/8"	BTC5R20UA	.935-.945"
3/4"	BTC5-R24UA	1.132-1.142"

## Large Diameter BobTail Data and Dimensions

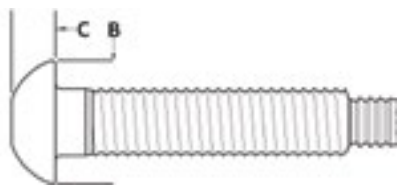

Round



Flanged



Truss



### Steel - Metric

Diameter	Part No.	Grip Range	Max Hole Size	[B] Head Dia (max)	[C] Head Height (max)	Min Shear (lbs)	Min Clamp (lbf)	Min Tensile (lbs)
<b>Flanged Head</b>								
16MM Grade 10.9	MBT-DT16-15G	10-20mm	17.5mm	33.8mm	12.2mm	116 kN	116 kN	163 kN
	MBT-DT16-20G	15-25mm	17.5mm	33.8mm	12.2mm	116 kN	116 kN	163 kN
	MBT-DT16-25G	20-30mm	17.5mm	33.8mm	12.2mm	116 kN	116 kN	163 kN
	MBT-DT16-30G	25-35mm	17.5mm	33.8mm	12.2mm	116 kN	116 kN	163 kN
	MBT-DT16-35G	30-40mm	17.5mm	33.8mm	12.2mm	116 kN	116 kN	163 kN
	MBT-DT16-40G	35-45mm	17.5mm	33.8mm	12.2mm	116 kN	116 kN	163 kN
	MBT-DT16-45G	40-50mm	17.5mm	33.8mm	12.2mm	116 kN	116 kN	163 kN
	MBT-DT16-50G	45-55mm	17.5mm	33.8mm	12.2mm	116 kN	116 kN	163 kN
	MBT-DT16-55G	50-60mm	17.5mm	33.8mm	12.2mm	116 kN	116 kN	163 kN
	MBT-DT16-60G	55-65mm	17.5mm	33.8mm	12.2mm	116 kN	116 kN	163 kN
20MM Grade 10.9	MBT-DT20-20G	15-25mm	22mm	42.4mm	16.0mm	182 kN	181 kN	255 kN
	MBT-DT20-30G	25-35mm	22mm	42.4mm	16.0mm	182 kN	181 kN	255 kN
	MBT-DT20-40G	35-45mm	22mm	42.4mm	16.0mm	182 kN	181 kN	255 kN
	MBT-DT20-45G	40-50mm	22mm	42.4mm	16.0mm	182 kN	181 kN	255 kN
	MBT-DT20-50G	45-55mm	22mm	42.4mm	16.0mm	182 kN	181 kN	255 kN

### Steel - Imperial

Diameter	Part No.	Grip Range	Max Hole Size	[B] Head Dia (max)	[C] Head Height (max)	Min Shear (lbs)	Min Clamp (lbf)	Min Tensile (lbs)
<b>Truss Head</b>								
5/8" Grade 5	BT30-BR20-4GA	.250-.620	.688	1.330	.340	22500	19000	27100
	BT30-BR20-8GA	.500-.870	.688	1.330	.340	22500	19000	27100
	BT30-BR20-12GA	.750-1.120	.688	1.330	.340	22500	19000	27100
	BT30-BR20-16GA	1.00-1.37	.688	1.330	.340	22500	19000	27100
	BT30-BR20-20GA	1.25-1.62	.688	1.330	.340	22500	19000	27100
<b>Round Head</b>								
3/4" Grade 5	BTR-BR24-8GA	.500-.870	.813	1.440	.530	32400	28400	40100

## BobTail Installation Tooling

### Tooling Selection (Inch)

Diameter	Tool	Installation Nose	Cutter Nose
3/16"	244BT 2480	99-7921 99-7921	99-7921CC —
1/4"	244BT SFBTT8-12	99-7932 —	99-7932CC —
5/16"	256BT SFBTT8-12	99-7923 —	99-7923CC —
3/8"	256BT SFBTT8-12	99-7924 —	99-7924CC —
1/2"	SF20	99-7882	99-7882CX
5/8"	SF20	99-7881	99-7881CX
3/4"	SF32	99-7894	99-7894CX
7/8"	SF46	99-7863	99-7863CX
1"	SF46	99-7867	99-7856CX

### Tooling selection (Metric)

Diameter	*Tool	Installation	Cutter
12mm	SF20	99-7880	99-7880CX
14mm	SF20	99-7884	99-7884CX
16mm	SF20	99-7881	99-7881CX
20mm	SF32	99-7893	99-7893CX

\* Marked tools require the following additional parts:

3-Tool Controller .....	128441-3
Relief Valve with Transducer .....	128415
Hydraulic Hose Assembly .....	125926-XX
Control Cord (Tool to Controller) .....	128418-XX
Cable Assembly (Transducer to Controller) .....	128457-XX
Cord Assembly (2-Wire controller to Powerig).....	118308-XX



Model SF46

Model SF20  
SWAGEFORWARD®

### Collar cutter feature



While BobTail fasteners install permanently, BobTail installation tooling features a collar cutter nosepiece that makes fastener removal easier than ever.



## C50L®

The fastener that has defined HuckBolts for more than 50 years.

The C50L® offers superior vibration resistance and overall durability for heavy-duty fastening jobs, and is ideal for use within applications where consistent, uniform high clamp force is required. Testing has proven that C50L fasteners meet, or exceed the performance of torqued bolts in both shear and tensile strength, as well as fatigue life. For heavy-duty applications ranging from railcar to mining equipment manufacturing, the C50L delivers superior vibration resistance and overall durability.

### Available Sizes:

1/2", 5/8", 3/4", 7/8", 1", 1-1/8", 1-3/8"

### Materials:

Steel, Aluminum

### Headstyles:

Round, Truss, Large Truss, 90° Flush, Thread Head



## Secure, Fast Installation

1. Swaged-on collar forms a permanent, vibration-proof connection.
2. Initial long length of fastener enables pull-out of large gaps.
3. Consistent, repeatable pre-load.

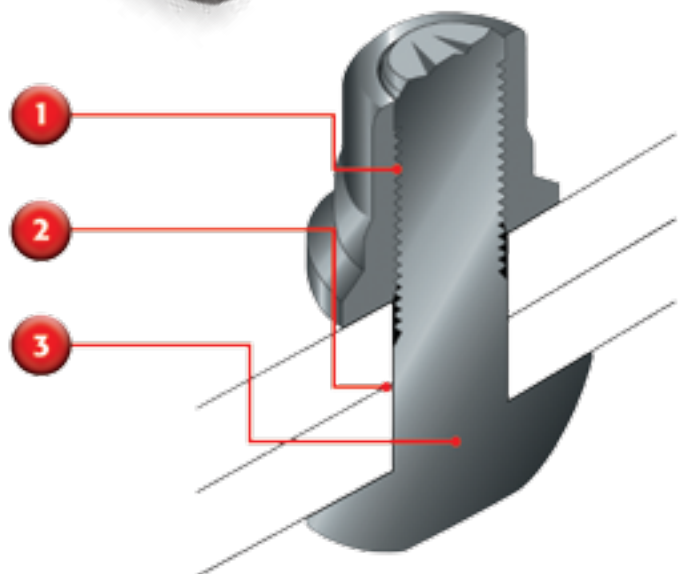

## Installation Sequence

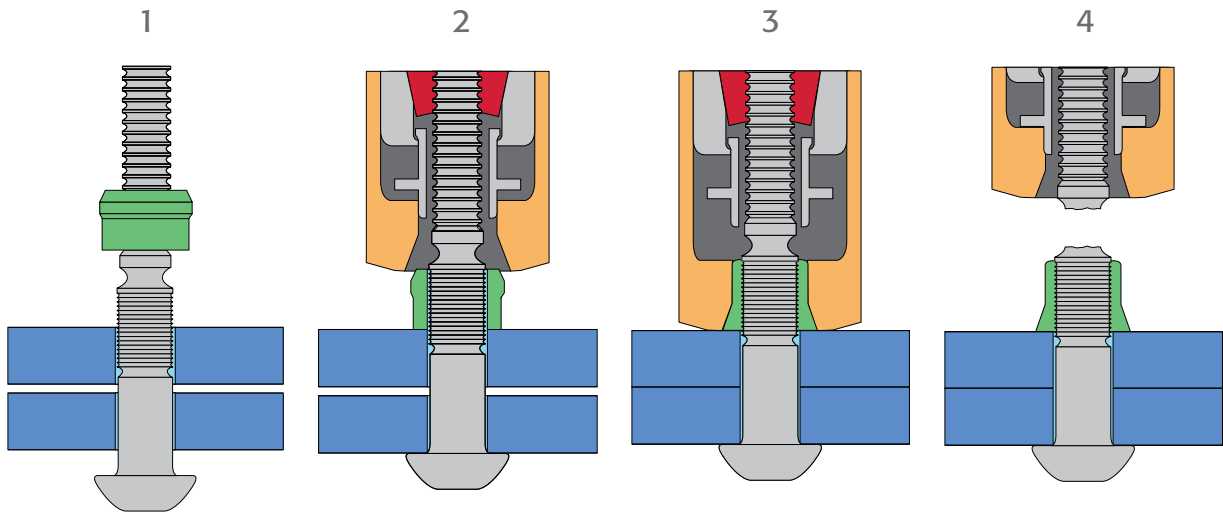

1  
The pin is inserted into the prepared hole and the smooth bore collar is placed on the pin.

2  
The installation tool is applied to the pintail. When the tool is activated, the jaws in the nose assembly pull on the pintail and the nose anvil pushes on the collar to remove any gap.

3  
The nose anvil starts to swage the collar into the lockgrooves on the pin. Continued swaging causes the collar to lengthen and develop clamp.

4  
When swaging of the collar into the lockgrooves is complete, the pintail separates from the pin which completes the installation cycle.



Unlike threaded fasteners, the C50L HuckBolt delivers consistent installation results. High costs of calibrating, maintaining, and replacing tools are eliminated. And installation does not require expensive, highly experienced workers.

## C50L Data and Dimensions



Round

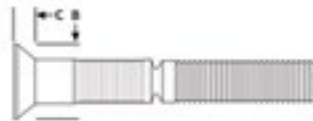

90 Degree Flush



80 Degree Flush

### Steel Pin - Black

Diameter	Part No.	Grip Range	Max Hole Size	[B] Head Dia (max)	[C] Head Height (max)	Typical Shear* (lbs)	Typical Clamp* (lbf)	Typical Tensile* (lbs)
<b>Round Head</b>								
1/2"	C50LR-BR16-4	.250-.500	.563	.906	.316	14400	12050	17050
	C50LR-BR16-8	.500-.750	.563	.906	.316	14400	12050	17050
	C50LR-BR16-12	.750-1.000	.563	.906	.316	14400	12050	17050
	C50LR-BR16-16	1.000-1.125	.563	.906	.316	14400	12050	17050
	C50LR-BR16-20	1.250-1.500	.563	.906	.316	14400	12050	17050
	C50LR-BR16-24	1.500-1.750	.563	.906	.316	14400	12050	17050
	C50LR-BR16-28	1.750-2.000	.563	.906	.316	14400	12050	17050
	C50LR-BR16-32	2.000-2.250	.563	.906	.316	14400	12050	17050
5/8"	C50LR-BR20-4	.250-.500	.688	1.141	.397	22500	19200	27100
	C50LR-BR20-8	.500-.750	.688	1.141	.397	22500	19200	27100
	C50LR-BR20-12	.750-1.000	.688	1.141	.397	22500	19200	27100
	C50LR-BR20-16	1.000-1.125	.688	1.141	.397	22500	19200	27100
	C50LR-BR20-20	1.250-1.500	.688	1.141	.397	22500	19200	27100
	C50LR-BR20-24	1.500-1.750	.688	1.141	.397	22500	19200	27100
3/4"	C50LR-BR24-8	.500-.750	.813	1.383	.495	32400	28400	40100
	C50LR-BR24-12	.750-1.000	.813	1.383	.495	32400	28400	40100
	C50LR-BR24-16	1.000-1.125	.813	1.383	.495	32400	28400	40100
	C50LR-BR24-20	1.250-1.500	.813	1.383	.495	32400	28400	40100
	C50LR-BR24-24	1.500-1.750	.813	1.383	.495	32400	28400	40100
	C50LR-BR24-28	1.750-2.000	.813	1.383	.495	32400	28400	40100
	C50LR-BR24-32	2.000-2.250	.813	1.383	.495	32400	28400	40100
	C50LR-BR24-36	2.250-2.500	.813	1.383	.495	32400	28400	40100
7/8"	C50LR-BR28-16	1.000-1.125	.938	1.610	.550	43400	39250	55450
	C50LR-BR28-20	1.250-1.500	.938	1.610	.550	43400	39250	55450
	C50LR-BR28-24	1.500-1.750	.938	1.610	.550	43400	39250	55450
	C50LR-BR28-28	1.750-2.000	.938	1.610	.550	43400	39250	55450
	C50LR-BR28-32	2.000-2.250	.938	1.610	.550	43400	39250	55450
	C50LR-BR28-36	2.250-2.500	.938	1.610	.550	43400	39250	55450
	C50LR-BR28-40	2.500-2.750	.938	1.610	.550	43400	39250	55450
1"	C50LR-BR32-20	1.250-1.500	1.063	1.850	.618	56500	51500	72700
	C50LR-BR32-24	1.500-1.750	1.063	1.850	.618	56500	51500	72700
	C50LR-BR32-28	1.750-2.000	1.063	1.850	.618	56500	51500	72700
	C50LR-BR32-32	2.000-2.250	1.063	1.850	.618	56500	51500	72700
	C50LR-BR32-36	2.250-2.500	1.063	1.850	.618	56500	51500	72700
	C50LR-BR32-44	2.750-3.000	1.063	1.850	.618	56500	51500	72700
	C50LR-BR32-48	3.000-3.250	1.063	1.850	.618	56500	51500	72700
	C50LR-BR32-52	3.250-3.500	1.063	1.850	.618	56500	51500	72700
	C50LR-BR32-56	3.500-3.750	1.063	1.850	.618	56500	51500	72700
	C50LR-BR32-60	3.750-4.000	1.063	1.850	.618	56500	51500	72700
	C50LR-BR32-64	4.000-4.250	1.063	1.850	.618	56500	51500	72700
C50LR-BR32-84	5.250-5.500	1.063	1.850	.618	56500	51500	72700	
C50LR-BR32-88	5.500-5.750	1.063	1.850	.618	56500	51500	72700	

NOTE: Part number listings reflect typical stock. Items not listed require a minimum order.  
\*For carbon steel pins.

## Steel Pin - Zinc Plated

Diameter	Part No.	Grip Range	Max Hole Size	[B] Head Dia (max)	[C] Head Height (max)	Typical Shear (lbs)	Typical Clamp (lbf)	Typical Tensile (lbs)
<b>Round Head</b>								
1/2"	C50LR-BR16-4GA	.250-.500	.563	.906	.316	14400	12050	17050
	C50LR-BR16-8GA	.500-.750	.563	.906	.316	14400	12050	17050
	C50LR-BR16-12GA	.750-1.000	.563	.906	.316	14400	12050	17050
	C50LR-BR16-16GA	1.000-1.125	.563	.906	.316	14400	12050	17050
5/8"	C50LR-BR20-4GA	.250-.500	.688	1.141	.397	22500	19200	27100
	C50LR-BR20-8GA	.500-.750	.688	1.141	.397	22500	19200	27100
	C50LR-BR20-12GA	.750-1.000	.688	1.141	.397	22500	19200	27100
	C50LR-BR20-16GA	1.000-1.125	.688	1.141	.397	22500	19200	27100
	C50LR-BR20-20GA	1.250-1.500	.688	1.141	.397	22500	19200	27100
3/4"	C50LR-BR24-12GA	.750-1.000	.813	1.383	.495	32400	28400	40100
<b>90° Flush Head</b>								
5/8"	C50L90-BR20-12	.750-1.000	.688	1.140	.313	22500	19200	27100
3/4"	C50L90-BR24-12	.750-1.000	.813	1.370	.375	32400	28400	40100
	C50L90-BR24-16	1.000-1.125	.813	1.370	.375	32400	28400	40100
	C50L90-BR24-20	1.250-1.500	.813	1.370	.375	32400	28400	40100
	C50L90-BR24-24	1.500-1.750	.813	1.370	.375	32400	28400	40100
	C50L90-BR24-28	1.750-2.000	.813	1.370	.375	32400	28400	40100
	C50L90-BR24-32	2.000-2.250	.813	1.370	.375	32400	28400	40100
<b>80° Flush Head</b>								
3/4"	C50L80-BR24-16	1.000-1.125	.813	1.250	.348	32400	28400	40100

NOTE: Part number listings reflect typical stock. Items not listed require a minimum order.

## C50L Lockbolt Collars

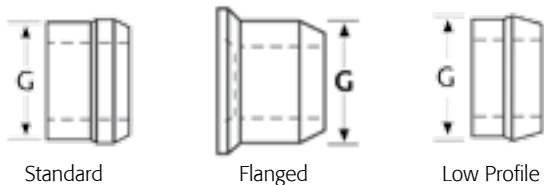

Steel, Zinc Plated

Diameter	Part No.	Width (G)
<b>Standard, Non-Flanged</b>		
1/2"	LC-2R16G	.765-.800
5/8"	LC-2R20G	.970-.985
3/4"	LC-2R24G	1.165-1.180
7/8"	LC-2R28G	1.360-1.375
1"	LC-2R32G	1.550-1.570
1-1/8"	LC-2R36G	1.750-1.770
<b>Flanged</b>		
1/2"	3LC-2R16G	.793-.807
5/8"	3LC-2R20G	.980-.996
5/8"	3LC-2R20GANL	.980-.996
3/4"	3LC-2R24G	1.175-1.195
7/8"	3LC-2R28G	1.360-1.370
1"	3LC-2R32G	1.550-1.565
<b>Low Profile</b>		
5/8"	8LC-2R20GA	.972-.982
7/8"	8LC-2R28G	1.360-1.375

## C50L Installation Tooling

Diameter	Installation Tool	Nose Assembly	Type
1/2"	2620	99-5000	Hydraulic
	2620PT	99-5002	Hydraulic
5/8"	2624/2628	99-5008	Hydraulic
	3585	99-5008	Hydraulic
3/4"	3585	99-5010	Hydraulic
7/8"	2630	99-5014	Hydraulic
1"	507	99-5016	Hydraulic
1-1/8"	507	99-5019	Hydraulic



## C6L®

The classic 6-groove locking fastener built with staying power.

A result of Huck International innovation a half-century ago, the versatile Arconic C6L® HuckBolt® remains the number one fastening system for applications that require a strong, vibration-resistant seal today.

C6L's exclusive locking groove design ensures a permanent fit that resists loosening. That means it's ideal for applications from general manufacturing to such high-vibration applications as HVAC, trailer and container assembly, rotary and rotating equipment, shopping carts, railroad and transit cars, geodesic structures, and many others.

In addition to offering superior fastening performance, the C6L system reduces labor and installation costs, along with rework and warranty expenses. For example, using the C6L eliminates the need to hire certified welders or specially trained employees, because workers can be instructed to install these foolproof fasteners in a matter of minutes.

The C6L is simply stronger, easier to install, and more durable than welding, adhesives, or conventional threaded fastening systems. The C6L is available in Grade 2, Grade 5, and Grade 8.

**Available Sizes:**

3/16", 1/4", 5/16", 3/8"

**Materials:**

Steel, Aluminum, Stainless Steel

**Headstyles:**

Round, Truss, Flush, 98T



### Secure, Fast Installation

1. Wide bearing collar and head spread load to ensure structural integrity
2. Corrosion resistant coatings can be painted
3. Excellent gap pull-out and high retained clamp
4. High fatigue annular lock groove form extends the life of your structure

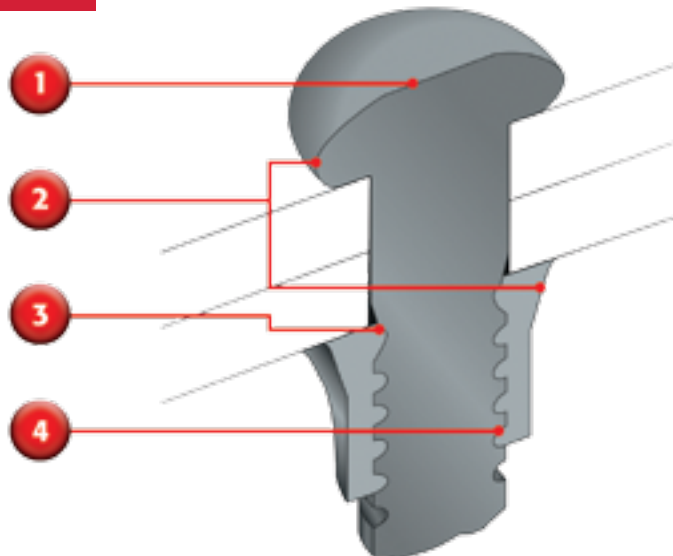



## Installation Sequence

The C6L's unique design virtually eliminates installation errors caused by operator or tool variables. The C6L ensures that once the collar swage is complete, the pintail breaks off and the fastener is tightly installed. No rework required. And you can count on consistent, high-uniform clamp force with every C6L installation, time after time.

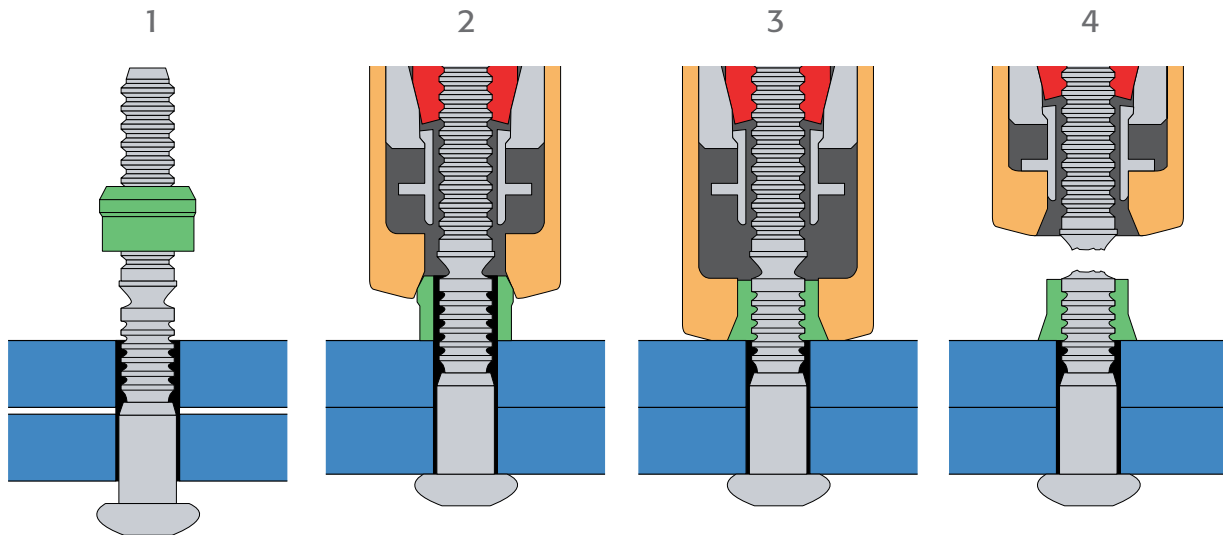

*The pin is inserted into the prepared hole and the smooth bore collar is placed on the pin.*

*The installation tool is applied to the pintail. When the tool is activated, the jaws in the nose assembly pull on the pintail and the nose anvil pushes on the collar to remove any gap.*

*The nose anvil starts to swage the collar into the lockgrooves on the pin. Continued swaging causes the collar to lengthen and develop clamp.*

*When swaging of the collar into the lockgrooves is complete, the pintail separates from the pin which completes the installation cycle.*



## C6L Data and Dimensions

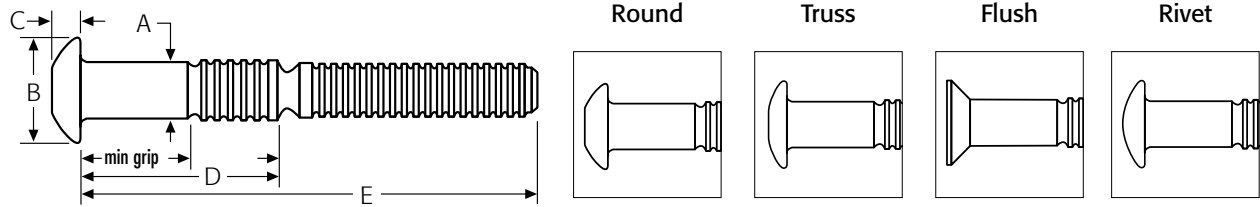

### Steel Pin - Zinc Plated

Diameter	Part No.	Grip Range	Max Hole Size*	[B] Head Dia (max)	[C] Head Height (max)	Typical Shear (lbs)	Typical Clamp (lbf)	Typical Tensile (lbs)
<b>Round Head</b>								
1/4"	C6LB-R8-2G	0.063-0.188	.312	.525	.152	3050	1805	3000
	C6LB-R8-3GA	0.125-0.250	.312	.525	.152	3050	1805	3000
	C6LB-R8-4G	0.188-0.313	.312	.525	.152	3050	1805	3000
	C6LB-R8-5G	0.250-0.375	.312	.525	.152	3050	1805	3000
	C6LB-R8-6G	0.313-0.438	.312	.525	.152	3050	1805	3000
	C6LB-R8-7G	0.375-0.500	.312	.525	.152	3050	1805	3000
	C6LB-R8-8G	0.438-0.563	.312	.525	.152	3050	1805	3000
5/16"	C6LB-R10-4G	0.125-0.375	.390	.656	.201	4725	2810	4600
	C6LB-R10-6G	0.250-0.500	.390	.656	.201	4725	2810	4600
	C6LB-R10-8G	0.375-0.625	.390	.656	.201	4725	2810	4600
3/8"	C6LB-R12-4G	0.125-0.375	.468	.787	.248	6825	4020	6500
	C6LB-R12-6G	0.250-0.500	.468	.787	.248	6825	4020	6500
	C6LB-R12-8G	0.375-0.625	.468	.787	.248	6825	4020	6500
	C6LB-R12-10G	0.500-0.750	.468	.787	.248	6825	4020	6500
	C6LB-R12-12G	0.625-0.875	.468	.787	.248	6825	4020	6500
C6LB-R12-14G	0.750-1.000	.468	.787	.248	6825	4020	6500	
<b>Truss Head</b>								
1/4"	C6LT-R8-4GA	0.188-0.313	.312	.594	.115	3050	1805	3000
	C6LT-R8-5GA	0.250-0.375	.312	.594	.115	3050	1805	3000
	C6LT-R8-7GA	0.375-0.500	.312	.594	.115	3050	1805	3000
	C6LT-R8-8GA	0.438-0.563	.312	.594	.115	3050	1805	3000
3/8"	C6LT-R12-4G	0.125-0.375	.468	.922	.202	6825	4020	6500
	C6LT-R12-6G	0.250-0.500	.468	.922	.202	6825	4020	6500
	C6LT-R12-8G	0.375-0.625	.468	.922	.202	6825	4020	6500
	C6LT-R12-10G	0.500-0.750	.468	.922	.202	6825	4020	6500

\*Uses 3LC collar

### Aluminum Pin

Diameter	Part No.	Grip Range	Max Hole Size	[B] Head Dia (max)	[C] Head Height (max)	Typical Shear (lbs)	Typical Clamp (lbf)	Typical Tensile (lbs)
<b>Round Head</b>								
1/4"	C6LB-C8-4	0.188-0.313	.266	.525	.152	1875	950	1800
3/8"	C6LB-C12-6	0.250-0.500	.391	.787	.248	4200	2200	4200
	C6LB-C12-8	0.375-0.625	.391	.787	.248	4200	2200	4200
	C6LB-C12-10	0.500-0.750	.391	.787	.248	4200	2200	4200
	C6LB-C12-12	0.625-0.875	.391	.787	.248	4200	2200	4200

NOTE: Part number listings reflect typical stock. Items not listed require a minimum order.

## Steel Pin - Zinc Plated - Stainless Steel Cap

Diameter	Part No.	Grip Range	Max Hole Size	[B] Head Dia (max)	[C] Head Height (max)	Typical Shear (lbs)	Typical Clamp (lbf)	Typical Tensile (lbs)
<b>Truss Head</b>								
1/4"	C6LTC-R8-3G	0.125-0.250	.266	.594	.115	3050	1805	3000
	C6LTC-R8-4G	0.188-0.313	.266	.594	.115	3050	1805	3000
	C6LTC-R8-5G	0.250-0.375	.266	.594	.115	3050	1805	3000
	C6LTC-R8-6G	0.313-0.438	.266	.594	.115	3050	1805	3000
	C6LTC-R8-7G	0.375-0.500	.266	.594	.115	3050	1805	3000
	C6LTC-R8-8G	0.438-0.563	.266	.594	.115	3050	1805	3000
3/8"	C6LTC-R8-9G	0.500-0.625	.266	.594	.115	3050	1805	3000
	C6LTC-R12-4G	0.188-0.313	.391	.922	.202	6825	4020	6500
	C6LTC-R12-6G	0.313-0.438	.391	.922	.202	6825	4020	6500
	C6LTC-R12-8G	0.438-0.563	.391	.922	.202	6825	4020	6500
	C6LTC-R12-10G	0.563-0.688	.391	.922	.202	6825	4020	6500
	C6LTC-R12-12G	0.688-0.813	.391	.922	.202	6825	4020	6500
C6LTC-R12-14G	0.813-0.938	.391	.922	.202	6825	4020	6500	

## Stainless Steel Pin

Diameter	Part No.	Grip Range	Max Hole Size	[B] Head Dia (max)	[C] Head Height (max)	Typical Shear (lbs)	Typical Clamp (lbf)	Typical Tensile (lbs)
<b>Rivet Head - Polished</b>								
3/16"	C98LT-U6-3BR	0.125-0.250	.203	.492	.106	2000	1025	1455
	C98LT-U6-5BR	0.250-0.375	.203	.492	.106	2000	1025	1455
	C98LT-U6-6BR	0.313-0.438	.203	.492	.106	2000	1025	1455
	C98LT-U6-7BR	0.375-0.500	.203	.492	.106	2000	1025	1455
	C98LT-U6-9BR	0.500-0.625	.203	.492	.106	2000	1025	1455
	C98LT-U6-10BR	0.563-0.688	.203	.492	.106	2000	1025	1455
	C98LT-U6-11BR	0.625-0.750	.203	.492	.106	2000	1025	1455
C98LT-U6-12BR	0.688-0.813	.203	.492	.106	2000	1025	1455	
<b>Round Head</b>								
1/4"	C6LB-U8-3	0.125-0.250	.266	.525	.152	3550	1805	2750
	C6LB-U8-4	0.188-0.313	.266	.525	.152	3550	1805	2750
	C6LB-U8-5	0.250-0.375	.266	.525	.152	3550	1805	2750
	C6LB-U8-6	0.313-0.438	.266	.525	.152	3550	1805	2750
	C6LB-U8-8	0.438-0.563	.266	.525	.152	3550	1805	2750
	C6LB-U8-9	0.500-0.625	.266	.525	.152	3550	1805	2750
3/8"	C6LB-U12-6	0.250-0.500	.391	.787	.248	7950	4020	6100
	C6LB-U12-8	0.375-0.625	.391	.787	.248	7950	4020	6100
	C6LB-U12-10	0.500-0.750	.391	.787	.248	7950	4020	6100
<b>Truss Head</b>								
3/8"	C6LT-U12-4	0.125-0.375	.391	.922	.202	7950	4020	6100
	C6LT-U12-6	0.250-0.500	.391	.922	.202	7950	4020	6100
	C6LT-U12-8	0.375-0.625	.391	.922	.202	7950	4020	6100
	C6LT-U12-10	0.500-0.750	.391	.922	.202	7950	4020	6100

NOTE: Part number listings reflect typical stock. Items not listed require a minimum order.



## C6L Lockbolt Collars



Flanged

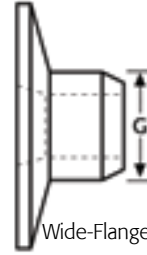

Wide-Flanged

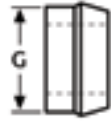

Non-Flanged

### Steel, Zinc Plated

Diameter	Part No.	Width (G)
<b>Non-Flanged</b>		
3/16"	2LC-R6G	.304-.311
1/4"	2LC-R8G	.402-.409
5/16"	2LC-R10G	.485-.494
3/8"	2LC-R12G	.590-.600
<b>Flanged</b>		
3/16"	3LC-2R6G	.304-.311
1/4"	3LC-2R8G	.402-.409
5/16"	3LC-2R10G	.498-.507
3/8"	3LC-2R12G	.599-.610
<b>Wide-Flanged</b>		
1/4"	3LCW-2R8G	.400-.409

### Aluminum

Diameter	Part No.	Width (G)
<b>Non-Flanged</b>		
3/16"	2LC-F6	.304-.311
1/4"	2LC-F8	.402-.409
5/16"	2LC-F10	.485-.494
3/8"	2LC-F12	.590-.600
<b>Flanged</b>		
1/4"	3LC-F8	.402-.409
5/16"	3LC-F10	.498-.507
3/8"	3LC-F12	.599-.610

### Stainless Steel

Diameter	Part No.	Width (G)
<b>Non-Flanged</b>		
3/16"	2LC-2CU6	.304-.311
1/4"	2LC-2CU8	.402-.409
3/8"	2LC-2CU12	.485-.494
<b>Flanged</b>		
3/16"	3LC-2CU6	.304-.311
1/4"	3LC-2CU8	.402-.409
3/8"	3LC-2CU12	.599-.610

### Installation Tooling

Diameter	Installation Tool	Nose Assembly	Type
3/16"	244X	99-2555-HD	Pneudraulic
	254	99-2558	Pneudraulic
	256	99-2558	Pneudraulic
	2025	99-3003	Pneudraulic
	2480	99-3003	Hydraulic
	2581	99-2558	Hydraulic
1/4"	244X	99-3417	Pneudraulic
	254	99-2564	Pneudraulic
	256	99-2564	Pneudraulic
	2025	99-3006	Pneudraulic
	2480	99-3006	Hydraulic
	2581	99-2564	Hydraulic
5/16"	254	99-99-245	Pneudraulic
	256	99-99-245	Pneudraulic
	2581	99-99-245	Hydraulic
3/8"	254	99-100-245	Pneudraulic
	256	99-100-245	Pneudraulic
	2581	99-100-245	Hydraulic



# Magna-Grip®

Offering a wide grip range and uniform installed values.

In applications where a wide grip range is required and a flush pin break to the collar is beneficial, Huck Magna-Grip® is the ideal fastener for the job. In fact, Magna-Grip's wide grip range can replace up to 4 traditional HuckBolts.

Like all Huck engineered fasteners, Magna-Grip offers the highest level of vibration resistance possible. Magna-Grip installs reliably, and consistently provides high, uniform installed values.

**Available Sizes:**

3/16", 1/4", 5/16", 3/8"

**Materials:**

Steel, Aluminum

**Headstyles:**

Button, Truss, Broad Truss, 90° Flush, 98T



## Secure, Fast Installation

1. Flush-breaking, lock-groove design provides a wide grip range to reduce inventory requirements.
2. Collar material swaged into the annular pin grooves forms a permanent, vibration-proof connection that promotes increased customer satisfaction and reduced warranty claims.
3. Hole preparation isn't critical. Built-in system values yield high, consistent clamp loads, and gap removal.

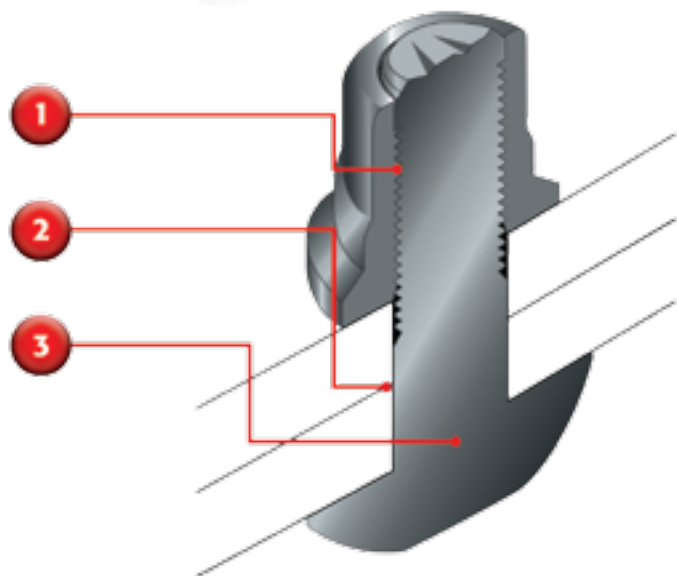



## Magna-Grip Head Style Options

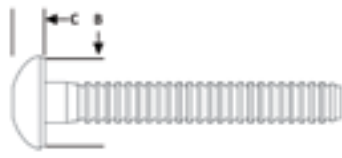

Button

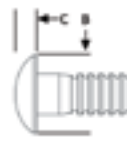

98T

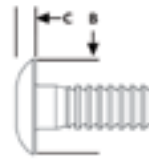

Truss

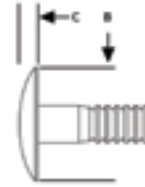

Broad Truss

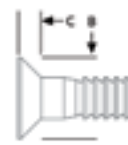

90 Degree Flush

## Steel Pin - Zinc Plated

Diameter	Part No.	Grip Range	Max Hole Size	[B] Head Dia (max)	[C] Head Height (max)	Typical Shear (lbs)	Typical Clamp (lbf)	Typical Tensile (lbs)
<b>Button Head</b>								
3/16"	MGPB-R6-10G	.062-.625	.219	.395	.129	2000	1500	2700
	MGPB-R6-20G	.312-1.250	.219	.395	.129	2000	1500	2700
1/4"	MGPB-R8-10G	.062-.625	.281	.520	.154	2700	2000	4000
	MGPB-R8-20G	.312-1.250	.281	.520	.154	2700	2000	4000
5/16"	MGPB-R10-12G	.125-.750	.359	.655	.206	3900	2900	6200
	MGPB-R10-22G	.625-1.375	.359	.655	.206	3900	2900	6200
3/8"	MGPB-R12-14G	.125-.875	.422	.780	.250	6000	4000	9000
	MGPB-R12-26G	.750-1.625	.422	.780	.250	6000	4000	9000
<b>98T Head</b>								
3/16"	MGP98T-R6-10G	.062-.625	.219	.488	.105	2000	1500	2700
	MGP98T-R6-10GP	.062-.625	.219	.488	.105	2000	1500	2700
	MGP98T-R6-20G	.312-1.250	.219	.488	.105	2000	1500	2700
<b>Truss Head</b>								
1/4"	MGPT-R8-10G	.062-.625	.281	.582	.120	2700	2000	4000
	MGPT-R8-10GP	.062-.625	.281	.582	.120	2700	2000	4000
	MGPT-R8-20G	.312-1.250	.281	.582	.120	2700	2000	4000
5/16"	MGPT-R10-12G	.125-.750	.359	.802	.149	3900	2900	6200
3/8"	MGPT-R12-14G	.125-.875	.422	.905	.175	6000	4000	9000
<b>Broad Truss Head</b>								
1/4"	MGP30-R8-10G	.062-.625	.281	.978	.165	2700	2000	4000
	MGP30-R8-24G	.062-1.500	.281	.978	.165	2700	2000	4000
3/8"	MGP30-R12-24G	.625-1.500	.422	1.259	.215	6000	4000	9000
	MGP30-R12-32G	1.125-2.000	.422	1.259	.215	6000	4000	9000
<b>90° Flush Head</b>								
3/16"	MGP90-R6-10G	.062-.625	.219	.361	.105	2000	1500	2700
1/4"	MGP90-R8-10G	.062-.625	.281	.475	.130	2700	2000	4000

NOTE: Part number listings reflect typical stock. Items not listed require a minimum order.



## Steel Pin - Cadmium Plated

Diameter	Part No.	Grip Range	Max Hole Size	[B] Head Dia (max)	[C] Head Height (max)	Typical Shear (lbs)	Typical Clamp (lbf)	Typical Tensile (lbs)
<b>Button Head</b>								
3/8"	MGPB-R12-14C	.125-.875	.422	.780	.250	6000	4000	9000
<b>98T Head</b>								
3/16"	MGP98T-R6-10C	.062-.625	.219	.488	.108	2000	1500	2700

## Steel Pin - Zinc Plated - Stainless Steel Cap

Diameter	Part No.	Grip Range	Max Hole Size	[B] Head Dia (max)	[C] Head Height (max)	Typical Shear (lbs)	Typical Clamp (lbf)	Typical Tensile (lbs)
<b>Truss Head</b>								
1/4"	MGPTR-R8-10G	.062-.625	.281	.582	.120	2700	2000	4000
3/8"	MGPTR-R12-14G	.125-.875	.422	.905	.210	6000	4000	9000

## Aluminum Pins

Diameter	Part No.	Grip Range	Max Hole Size	[B] Head Dia (max)	[C] Head Height (max)	Typical Shear (lbs)	Typical Clamp (lbf)	Typical Tensile (lbs)
<b>Button Head</b>								
3/16"	MGPB-E6-10	.062-.625	.219	.395	.129	1000	800	1300
1/4"	MGPB-E8-10	.062-.625	.281	.520	.154	1600	1400	2500
	MGPB-E8-20	.312-1.250	.281	.520	.154	1600	1400	2500
5/16"	MGPB-E10-12	.125-.750	.359	.655	.206	2700	2200	4100
3/8"	MGPB-E12-14	.125-.875	.422	.780	.250	3900	3200	5500
<b>98T Head</b>								
3/16"	MGP98T-E6-10	.062-.625	.219	.488	.108	1000	800	1300
	MGP98T-E6-20	.312-1.250	.219	.488	.108	1000	800	1300
<b>Truss Head</b>								
1/4"	MGPTR-E8-10	.062-.625	.281	.582	.120	1600	1400	2500
<b>Broad Truss Head</b>								
3/8"	MGP30-E12-24	.625-1.500	.422	1.259	.215	3900	3200	5500
<b>90° Flush Head</b>								
3/16"	MGP90-E6-10	.062-.625	.219	.361	.105	1000	800	1300
1/4"	MGP90-E8-10	.062-.625	.281	.475	.130	1600	1400	2500

NOTE: Part number listings reflect typical stock. Items not listed require a minimum order.



## Magna-Grip Lockbolt Collars

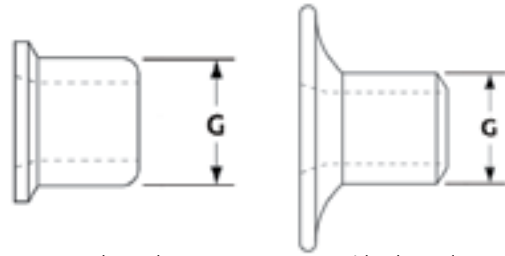

Flanged

Wide-Flanged

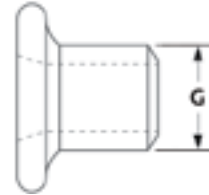

Medium-Flanged

	Diameter	Part No.	Width(G)
<b>Steel - Zinc Plated</b>			
Flanged	3/16"	MGC-R6U	.305-.315
	1/4"	MGC-R8U	.395-.405
	5/16"	MGC-R10U	.500-.510
	3/8"	MGC-R12U	.602-.612
Medium Flange	3/16"	MGCS-R6U	.305-.315
Wide Flange	3/16"	MGCW-R6U	.305-.315
	1/4"	MGCW-R8U	.395-.405
<b>Steel - Cadmium Plated</b>			
Flanged	3/16"	MGC-R6C	.305-.315
	1/4"	MGC-R8C	.395-.405
	3/8"	MGC-R12C	.375-.385
<b>Aluminum</b>			
Flanged	3/16"	MGC-F6	.305-.315
	1/4"	MGC-F8	.395-.405
	5/16"	MGC-F10	.500-.510
	3/8"	MGC-F12	.602-.612
Wide Flange	3/16"	MGCW-F6	.305-.315

## Magna-Grip Installation Tooling

Diameter	Installation Tool	Nose Assembly	Type
3/16"	2024	99-3201	Pneudraulic
	2025	99-3201	Pneudraulic
	255	99-3206	Pneudraulic
	256	99-3206	Pneudraulic
	2480	99-3201	Hydraulic
	2580	99-3206	Hydraulic
1/4"	2024	99-3204	Pneudraulic
	2025	99-3204	Pneudraulic
	255	99-3207	Pneudraulic
	256	99-3207	Pneudraulic
	2480	99-3204	Hydraulic
	2580	99-3207	Hydraulic
5/16"	255	99-1439	Pneudraulic
	256	99-1439	Pneudraulic
	2580	99-1439	Pneudraulic
	2600	99-3217	Pneudraulic
3/8"	255	99-1440*	Pneudraulic
	256	99-1440	Pneudraulic
	2580	99-1440	Hydraulic
	2600	99-3220	Hydraulic
	2620PT	H99-1492	Hydraulic

\* Aluminum Only



# Hucktainer®

Two-piece specialty fastener for fiberglass reinforced plywood panels.

The Hucktainer® specialty fastener installs with a consistent pressure, reducing the potential for crushing or crazing FRP panels and metal-clad applications. Each features a heavy zinc plating that resists corrosion, and an integral seal that helps keep the elements and other contaminants from invading the joint. Unlike threaded fasteners, Hucktainer is never over-torqued or under-torqued. Consistent clamp and fast, foolproof installation is what you'll get every time with Hucktainer.

Designed specifically for truck trailers, truck bodies, cargo containers, and other structures fabricated from fiberglass reinforced plywood, Hucktainer fasteners provide the consistent clamp and fast, foolproof installation required for maximum product quality and productivity.

**Available Sizes:**

3/8"

**Materials:**

Steel

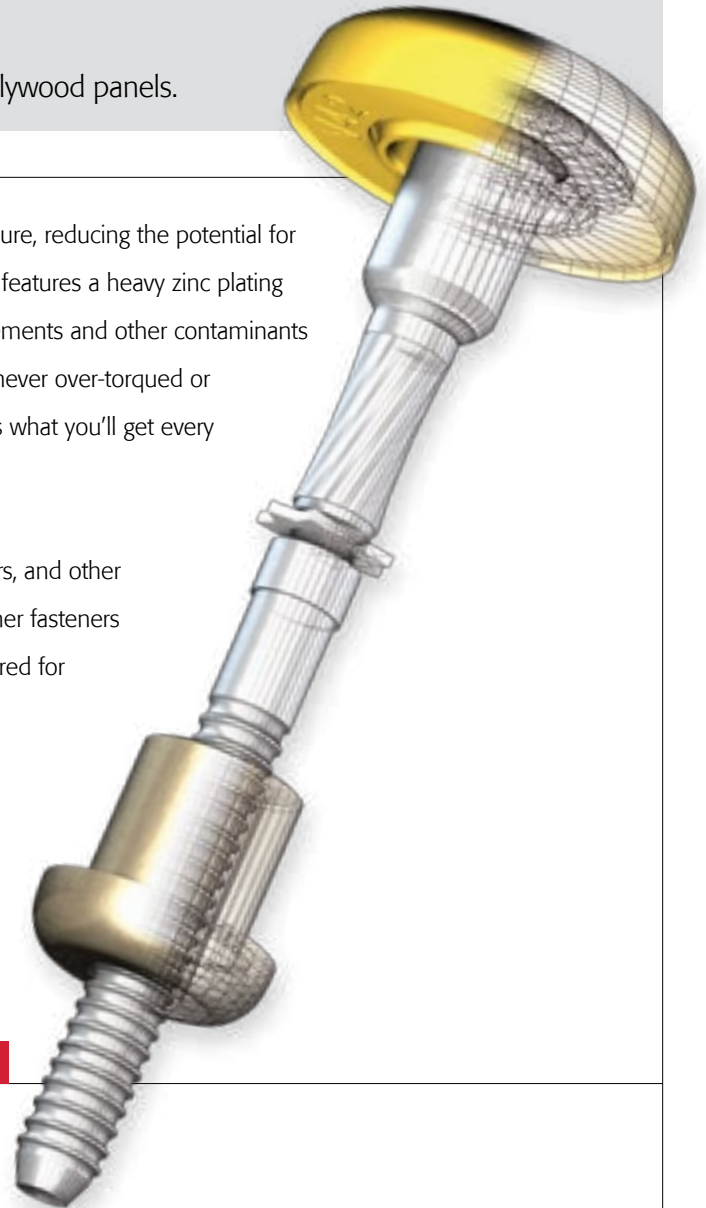

## Weather-Resistant Seal

1. Lower profile head design saves cargo space
2. Heads may be plastic-encapsulated for maximum corrosion-resistance; UV-resistant head capsules are colorfast and won't fade
3. Integral weather-resistant seal provides protection from the elements
4. Heavy-zinc plating protects against corrosion and preserves good looks
5. One sleeve fits all pins; no need to mix and match

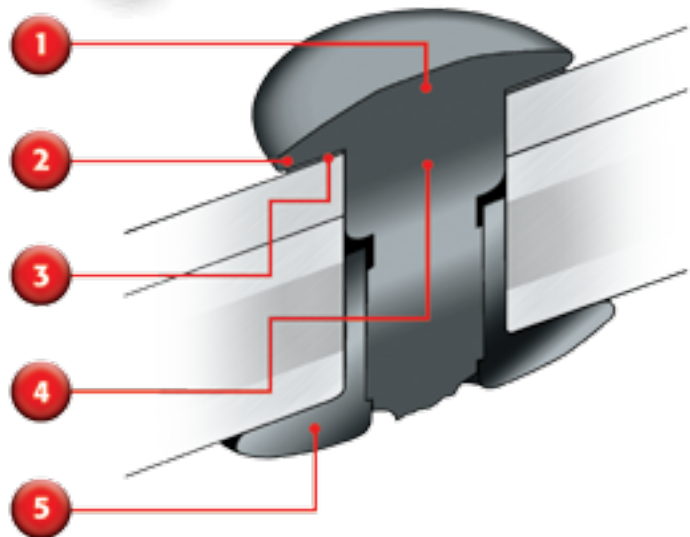

## Installation Sequence

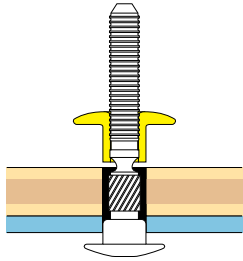

The pin and sleeve are inserted into the prepared hole.

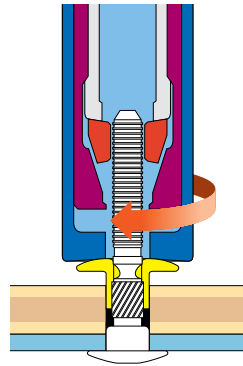

The installation tool is applied to the pintail. When the tool is activated, the sleeve is forced onto the spiral lock of the pin. The rotating action of the nose assembly allows the sleeve to turn freely.

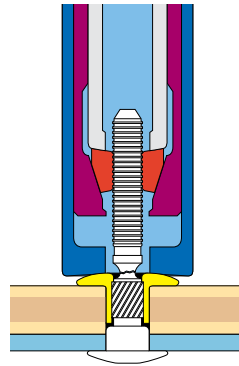

The sleeve is fully engaged on the pin and locks onto the pin's splines to clamp the material tightly together.

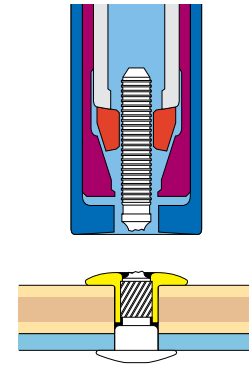

Continued pull of the tool causes the pintail to break away, which completes the installation cycle.

## Hucktainer Data & Dimensions



Standard

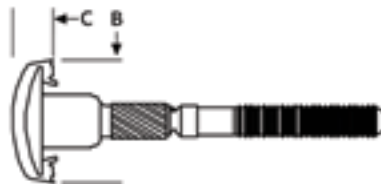

Medium-Bearing Encapsulated

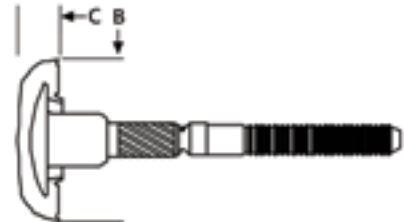

Wide-Bearing Encapsulated

## Steel Pin - Zinc Plated

Diameter	Part No.	Grip Range	Max Hole Size	[B] Head Dia (max)	[C] Head Height (max)	Typical Clamp (lbf)	Typical Tensile (lbs)		
							Min Grip	Mid Grip	Max Grip
<b>Standard Head</b>									
3/8"	HLPP-R12-10PL	.562-.687	.421	.830	.160	700	800	1200	1800
	HLPP-R12-11PL	.625-.750	.421	.830	.160	700	800	1200	1800
	HLPP-R12-12PL	.687-.812	.421	.830	.160	700	800	1200	1800
	HLPP-R12-13PL	.750-.875	.421	.830	.160	700	800	1200	1800
	HLPP-R12-14PL	.812-.937	.421	.830	.160	700	800	1200	1800
	HLPP-R12-15PL	.875-1.000	.421	.830	.160	700	800	1200	1800
	HLPP-R12-16PL	.937-1.062	.421	.830	.160	700	800	1200	1800
	HLPP-R12-17PL	1.000-1.125	.421	.830	.160	700	800	1200	1800
	HLPP-R12-18PL	1.062-1.187	.421	.830	.160	700	800	1200	1800
	HLPP-R12-19PL	1.125-1.250	.421	.830	.160	700	800	1200	1800
HLPP-R12-20PL	1.187-1.312	.421	.830	.160	700	800	1200	1800	

NOTE: Part number listings reflect typical stock. Items not listed require a minimum order.



## Steel Pin - Zinc Plated

Diameter	Part No.	Grip Range	Max Hole Size	[B] Head Dia (max)	[C] Head Height (max)	Typical Clamp (mid grip)	Typical Tensile (lbs)		
							Min Grip	Mid Grip	Max Grip
<b>Medium Bearing Encapsulated Head - Gray</b>									
3/8"	HLPMG-R12-9PL	.500-.625	.421	.950	.300	700	800	1200	1800
	HLPMG-R12-10PL	.562-.687	.421	.950	.300	700	800	1200	1800
	HLPMG-R12-11PL	.625-.750	.421	.950	.300	700	800	1200	1800
	HLPMG-R12-12PL	.687-.812	.421	.950	.300	700	800	1200	1800
	HLPMG-R12-13PL	.750-.875	.421	.950	.300	700	800	1200	1800
	HLPMG-R12-14PL	.812-.937	.421	.950	.300	700	800	1200	1800
	HLPMG-R12-15PL	.875-1.000	.421	.950	.300	700	800	1200	1800
	HLPMG-R12-16PL	.937-1.062	.421	.950	.300	700	800	1200	1800
	HLPMG-R12-17PL	1.000-1.125	.421	.950	.300	700	800	1200	1800
	HLPMG-R12-18PL	1.062-1.187	.421	.950	.300	700	800	1200	1800
HLPMG-R12-19PL	1.125-1.250	.421	.950	.300	700	800	1200	1800	
<b>Medium Bearing Encapsulated Head - White</b>									
3/8"	HLPMW-R12-9PL	.500-.625	.421	.950	.300	700	800	1200	1800
	HLPMW-R12-10PL	.562-.687	.421	.950	.300	700	800	1200	1800
	HLPMW-R12-11PL	.625-.750	.421	.950	.300	700	800	1200	1800
	HLPMW-R12-12PL	.687-.812	.421	.950	.300	700	800	1200	1800
	HLPMW-R12-13PL	.750-.875	.421	.950	.300	700	800	1200	1800
	HLPMW-R12-14PL	.812-.937	.421	.950	.300	700	800	1200	1800
	HLPMW-R12-15PL	.875-1.000	.421	.950	.300	700	800	1200	1800
	HLPMW-R12-16PL	.937-1.062	.421	.950	.300	700	800	1200	1800
	HLPMW-R12-17PL	1.000-1.125	.421	.950	.300	700	800	1200	1800
	HLPMW-R12-18PL	1.062-1.187	.421	.950	.300	700	800	1200	1800
<b>Medium Bearing Encapsulated Head - Hertz Yellow</b>									
3/8"	HLPMHY-R12-9PL	.500-.625	.421	.950	.300	700	800	1200	1800
	HLPMHY-R12-10PL	.562-.687	.421	.950	.300	700	800	1200	1800
	HLPMHY-R12-11PL	.625-.750	.421	.950	.300	700	800	1200	1800
	HLPMHY-R12-12PL	.687-.812	.421	.950	.300	700	800	1200	1800
	HLPMHY-R12-13PL	.750-.875	.421	.950	.300	700	800	1200	1800
	HLPMHY-R12-14PL	.812-.937	.421	.950	.300	700	800	1200	1800
	HLPMHY-R12-15PL	.875-1.000	.421	.950	.300	700	800	1200	1800
	HLPMHY-R12-16PL	.937-1.062	.421	.950	.300	700	800	1200	1800
	HLPMHY-R12-17PL	1.000-1.125	.421	.950	.300	700	800	1200	1800
	HLPMHY-R12-18PL	1.062-1.187	.421	.950	.300	700	800	1200	1800
HLPMHY-R12-19PL	1.125-1.250	.421	.950	.300	700	800	1200	1800	
<b>Medium Bearing Encapsulated Head - Ryder Yellow</b>									
3/8"	HLPMPRY-R12-9PL	.500-.625	.421	.950	.300	700	800	1200	1800
	HLPMPRY-R12-10PL	.562-.687	.421	.950	.300	700	800	1200	1800
	HLPMPRY-R12-11PL	.625-.750	.421	.950	.300	700	800	1200	1800
	HLPMPRY-R12-12PL	.687-.812	.421	.950	.300	700	800	1200	1800
	HLPMPRY-R12-13PL	.750-.875	.421	.950	.300	700	800	1200	1800
	HLPMPRY-R12-14PL	.812-.937	.421	.950	.300	700	800	1200	1800
	HLPMPRY-R12-15PL	.875-1.000	.421	.950	.300	700	800	1200	1800
	HLPMPRY-R12-16PL	.937-1.062	.421	.950	.300	700	800	1200	1800
	HLPMPRY-R12-17PL	1.000-1.125	.421	.950	.300	700	800	1200	1800
	HLPMPRY-R12-18PL	1.062-1.187	.421	.950	.300	700	800	1200	1800
HLPMPRY-R12-19PL	1.125-1.250	.421	.950	.300	700	800	1200	1800	
<b>Wide Bearing Encapsulated Head - Gray</b>									
3/8"	HLPEG-R12-9PL	.500-.625	.421	1.210	.325	700	800	1200	1800
	HLPEG-R12-10PL	.562-.687	.421	1.210	.325	700	800	1200	1800
	HLPEG-R12-11PL	.625-.750	.421	1.210	.325	700	800	1200	1800
	HLPEG-R12-12PL	.687-.812	.421	1.210	.325	700	800	1200	1800
	HLPEG-R12-13PL	.750-.875	.421	1.210	.325	700	800	1200	1800
	HLPEG-R12-14PL	.812-.937	.421	1.210	.325	700	800	1200	1800
	HLPEG-R12-15PL	.875-1.000	.421	1.210	.325	700	800	1200	1800

NOTE: Part number listings reflect typical stock. Items not listed require a minimum order.

## Steel Pin - Zinc Plated

Diameter	Part No.	Grip Range	Max Hole Size	[B] Head Dia (max)	[C] Head Height (max)	Typical Clamp (lbf)	Typical Tensile (lbs)			
							Min Grip	Mid Grip	Max Grip	
<b>Wide Bearing Encapsulated Head - Gray</b>										
3/8"	HLPEG-R12-16PL	.937-1.062	.421	1.210	.325	700	800	1200	1800	
	HLPEG-R12-17PL	1.000-1.125	.421	1.210	.325	700	800	1200	1800	
	HLPEG-R12-18PL	1.062-1.187	.421	1.210	.325	700	800	1200	1800	
	HLPEG-R12-19PL	1.125-1.250	.421	1.210	.325	700	800	1200	1800	
<b>Wide Bearing Encapsulated Head - White</b>										
3/8"	HLPEW-R12-9PL	.500-.625	.421	1.210	.325	700	800	1200	1800	
	HLPEW-R12-10PL	.562-.687	.421	1.210	.325	700	800	1200	1800	
	HLPEW-R12-11PL	.625-.750	.421	1.210	.325	700	800	1200	1800	
	HLPEW-R12-12PL	.687-.812	.421	1.210	.325	700	800	1200	1800	
	HLPEW-R12-13PL	.750-.875	.421	1.210	.325	700	800	1200	1800	
	HLPEW-R12-14PL	.812-.937	.421	1.210	.325	700	800	1200	1800	
	HLPEW-R12-15PL	.875-1.000	.421	1.210	.325	700	800	1200	1800	
	HLPEW-R12-16PL	.937-1.062	.421	1.210	.325	700	800	1200	1800	
	HLPEW-R12-17PL	1.000-1.125	.421	1.210	.325	700	800	1200	1800	
3/8"	HLPEW-R12-18PL	1.062-1.187	.421	1.210	.325	700	800	1200	1800	
	HLPEW-R12-19PL	1.125-1.250	.421	1.210	.325	700	800	1200	1800	
	<b>Wide Bearing Encapsulated Head - Hertz Yellow</b>									
	3/8"	HLPEHY-R12-9PL	.500-.625	.421	1.210	.325	700	800	1200	1800
		HLPEHY-R12-10PL	.562-.687	.421	1.210	.325	700	800	1200	1800
		HLPEHY-R12-11PL	.625-.750	.421	1.210	.325	700	800	1200	1800
		HLPEHY-R12-12PL	.687-.812	.421	1.210	.325	700	800	1200	1800
		HLPEHY-R12-13PL	.750-.875	.421	1.210	.325	700	800	1200	1800
		HLPEHY-R12-14PL	.812-.937	.421	1.210	.325	700	800	1200	1800
HLPEHY-R12-15PL		.875-1.000	.421	1.210	.325	700	800	1200	1800	
HLPEHY-R12-16PL		.937-1.062	.421	1.210	.325	700	800	1200	1800	
HLPEHY-R12-17PL		1.000-1.125	.421	1.210	.325	700	800	1200	1800	
3/8"	HLPEHY-R12-18PL	1.062-1.187	.421	1.210	.325	700	800	1200	1800	
	HLPEHY-R12-19PL	1.125-1.250	.421	1.210	.325	700	800	1200	1800	
	<b>Wide Bearing Encapsulated Head - Ryder Yellow</b>									
	3/8"	HLPERY-R12-9PL	.500-.625	.421	1.210	.325	700	800	1200	1800
		HLPERY-R12-10PL	.562-.687	.421	1.210	.325	700	800	1200	1800
		HLPERY-R12-11PL	.625-.750	.421	1.210	.325	700	800	1200	1800
		HLPERY-R12-12PL	.687-.812	.421	1.210	.325	700	800	1200	1800
		HLPERY-R12-13PL	.750-.875	.421	1.210	.325	700	800	1200	1800
		HLPERY-R12-14PL	.812-.937	.421	1.210	.325	700	800	1200	1800
HLPERY-R12-15PL		.875-1.000	.421	1.210	.325	700	800	1200	1800	
HLPERY-R12-16PL		.937-1.062	.421	1.210	.325	700	800	1200	1800	
HLPERY-R12-17PL		1.000-1.125	.421	1.210	.325	700	800	1200	1800	
3/8"	HLPERY-R12-18PL	1.062-1.187	.421	1.210	.325	700	800	1200	1800	
	HLPERY-R12-19PL	1.125-1.250	.421	1.210	.325	700	800	1200	1800	

Minimum orders may apply

## Hucktainer Sleeves - Zinc Plated



**Clearance Sleeve**  
HLPSC-R12

**Medium Bearing Sleeve**  
HLPMS-R12

**Large Bearing Sleeve**  
HLPS-R12

## Installation Tooling

Diameter	Installation Tool	Nose Assembly	Type
3/8"	2025	99-3464	Pneudraulic
	256	99-3438	Pneudraulic
	2480	99-3464	Hydraulic
	2580	99-3438	Hydraulic

NOTE: Part number listings reflect typical stock. Items not listed require a minimum order.

# Huck 360®

The engineered nut-and-bolt fastening system from the leader in vibration-resistant fastening, Huck.

The goal was simple: to design a high-strength bolting system that resists vibration loosening, no matter how extreme the environment. This system should offer quick installation and removal with conventional tools, deliver superior fatigue strength, and hold tight under high spike loads.

The result is the Huck 360®, the most advanced nut-and-bolt fastening system you'll find on the market today. Easy-to-install, the Huck 360 is engineered to be virtually maintenance-free and resistant to vibration, even under extreme conditions.

**Available Sizes:**

3/8", 1/2", 5/8", 3/4", 7/8", 1", 1-1/8", 1-3/8"  
10mm, 12mm, 16mm, 20mm, and 36mm

**Materials:**

Steel

Contact Alcoa Fastening Systems & Rings for availability.



## The Difference is in the Design



Huck 360® stays tight under severe vibration loading by eliminating the "gap" around the crest of the bolt. When tightened, the Huck 360 fills this gap, which prevents transverse motion between the 360 nut and bolt, keeping the assembly in place.

**Huck 360®**

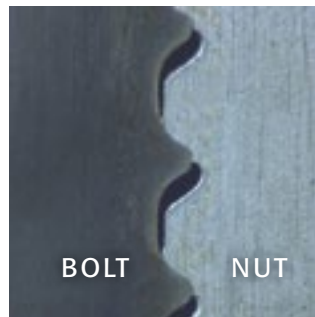

Thread flanks are locked.  
Nut cannot move relative to bolt.

**Conventional thread**



Thread flanks can slide.  
Nut can move relative to bolt.

## Transverse Vibration Comparison

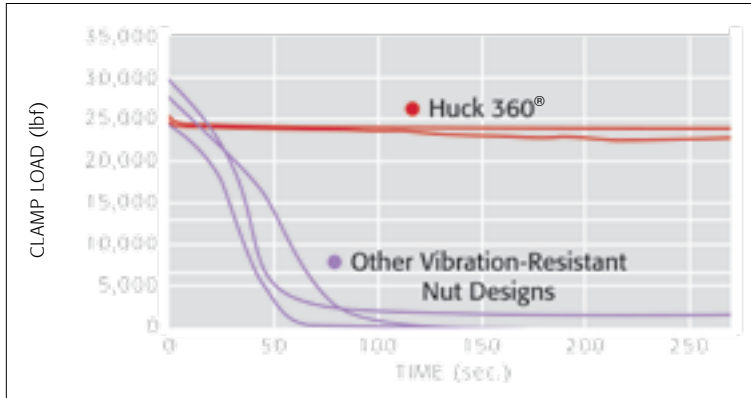

This chart shows that once vibration begins, clamp load quickly decays with conventional nuts and bolts, while it holds constant with Huck 360®.

## Increased Life

Because the Huck 360® was designed with shallow, low-notch factor bolt threads (the grooves aren't rolled as deep as a conventional bolt), the effective area of the fastener itself is widened by as much as 20%, increasing tensile and fatigue strength. In fact, the Huck 360 thread delivers 5 times the fatigue life of a standard thread bolt.



### Improved Fatigue Performance

Finite Element Analysis (FEA) reveals that the shallow thread form of the Huck 360® results in 27% less axial stress in the root than conventional bolt threads. Stress concentration is the primary contributing factor leading to fatigue failures.

Huck 360®

Conventional thread

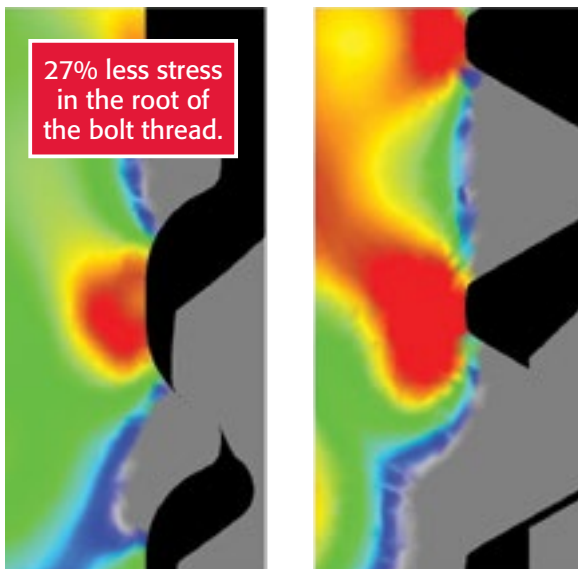

### Reduce Maintenance, Save Time

The Huck 360® installs faster and more easily than the nuts and bolts you're accustomed to using, and maintenance intervals can be extended. The Huck 360's superior fatigue strength has proven to increase equipment uptime and productivity.

### Huck 360® Benefits

- Resists vibration loosening.
- Withstands high spike loads.
- Increases equipment uptime.
- Installs 300% faster than conventional locknuts.
- Can be installed and removed with conventional tools.

# Huck Structural Blind Rivets



## When High Performance and Holding Power are Critical

Huck Structural Blind Rivets are Arconic's answer to loosening and vibration challenges. And it's the reason they are the world's strongest, most reliable, most consistent blind fastening solution available.

In fact, in fatigue tests, Huck Structural Blind Rivets outlasted the competition by almost 20-to-1. Engineered with a unique locking design, many of the Huck Structural Blind Rivets create an internal lock during installation that virtually eliminates pin pushout by mechanically locking the pin to the sleeve. Each locks permanently, reliably into place, with little effort.

Always accurate and easy to install, Huck Structural Blind Rivets offer quick one-worker installation. Inspections are simple to perform; no need for torque inspections or x-rays.

In applications where vibration resistance, reliability, and strong hold are critical, Huck Structural Blind Rivets offer the strength and durability needed. No fastening system is more dependable.

## Sheet-Line Bulb Comparison

Even in minimum-grip applications, Huck fasteners outperform the competition. They're engineered to form a bulb directly on the sheet line, precisely where it's needed, to prevent pull-through.



### Auto-Bulb™

Bulb forms directly on sheet line.



### The Competition

Bulb forms irregularly above sheet line resulting in lower installed values.

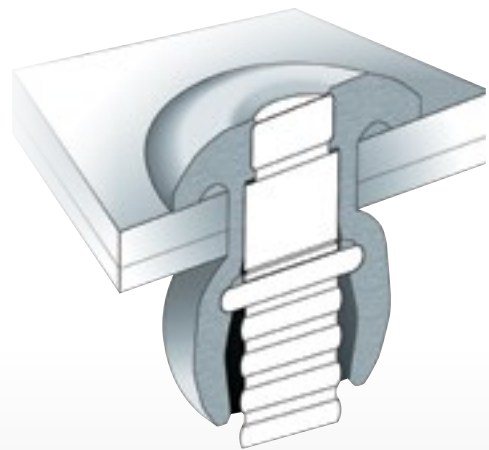

HuckLoK's proprietary solid circle lock ensures maximum strength and vibration resistance. Shear ring at sheet line provides consistent clamp.



## Types



### Magna-Lok®

Hole-filling fastener with excellent gap pull-out and moisture resistance. Solid circle lock creates internal lock that virtually eliminates pin push-out.



### Magna-Bulb®

Wide grip range fastener that forms a bulb directly on the sheet line. Offers a broader bearing surface.

### HuckLok®

Wide 1/4" grip range, double-locking action clamps assembly from both sides for maximum joint integrity.



### Auto-Bulb™

Features a tapered lead-in point for automated, high-speed assemblies. Forms a bulb directly on the sheet line, preventing pull-through. Available in stainless steel.



### Magna-Tite®

Has water-resistant sealant for oversize holes and repairs. Large blind-side footprint for use in thin or low-strength materials.



### BOM®

Blind, Oversize, Mechanically locked fasteners. Unique push-and-pull installation design for ultimate locking strength from blind-side install.

### FloorTight®

Self-countersinking design for consistent installations in plywood and plymetal vehicle floor applications.



# Magna-Lok®

The hole-filling fastener with mechanical circle lock and wide grip range.

The 360° solid-circle lock. It's Alcoa Fastening System's answer to loosening and vibration challenges. And it's the reason Magna-Lok® is the world's strongest, most reliable, most consistent blind fastening solution available. The unique locking design creates an internal lock during installation that virtually eliminates pin pushout by mechanically locking the pin to the sleeve. So Magna-Lok fasteners lock flush into place reliably. Permanently.

In lab shear fatigue tests, steel Magna-Lok fasteners outlasted the nearest competitor nearly 20 to 1. Ours lasted 2 million cycles, while theirs lasted only 100,000. In addition, this strength extends to the solid-circle lock design. The expanding sleeve creates a tough, long-lasting joint with a tight, weather-resistant seal. This shield blocks out water and salt, further ensuring the fastener's long, reliable life.

#### Available Sizes:

3/16", 1/4", 3/8", 1/2"

#### Materials:

Steel, Aluminum, Stainless Steel

#### Headstyles:

Protruding, Truss, 100° Flush

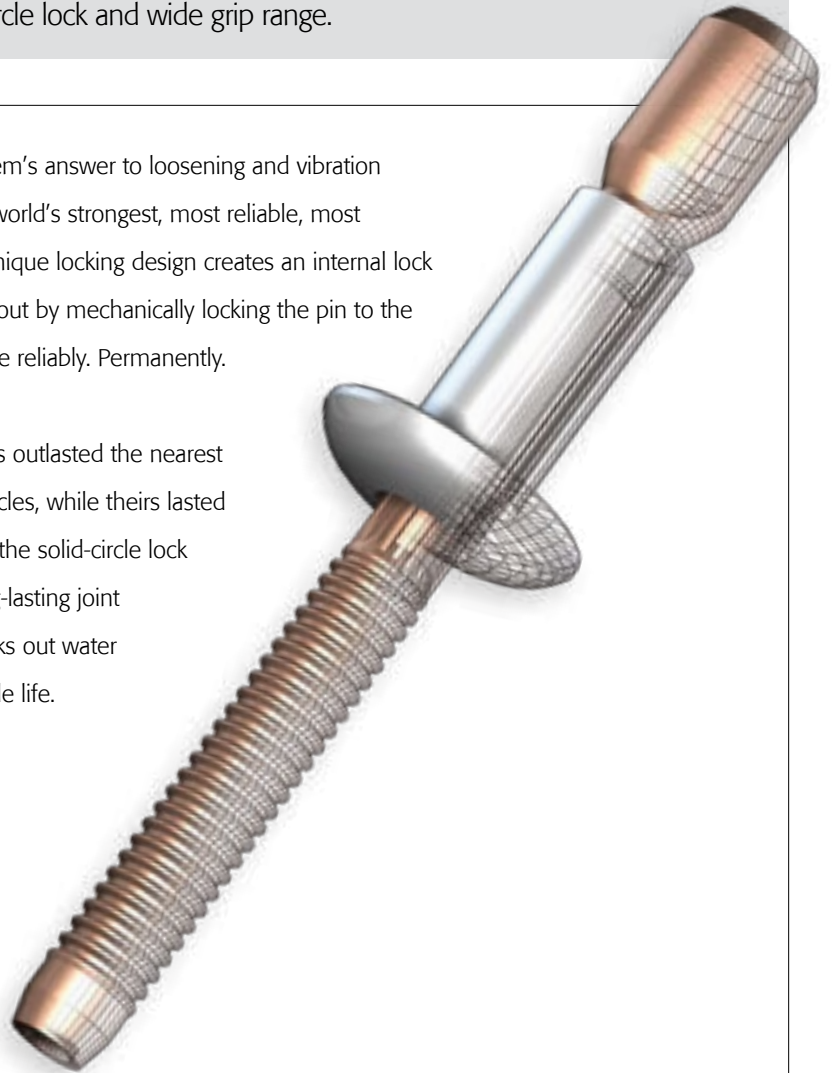

## Secure, Fast Installation

1. Flush pin break eliminates grinding and filling, leaving an even surface.
2. Unique, solid-circle lock ensures maximum strength and vibration resistance. The potential for pin push-out is virtually eliminated.
3. Excellent gap pull-out and high retained clamp.
4. Sleeve expands during installation to fill the hole and create a moisture-resistant joint.

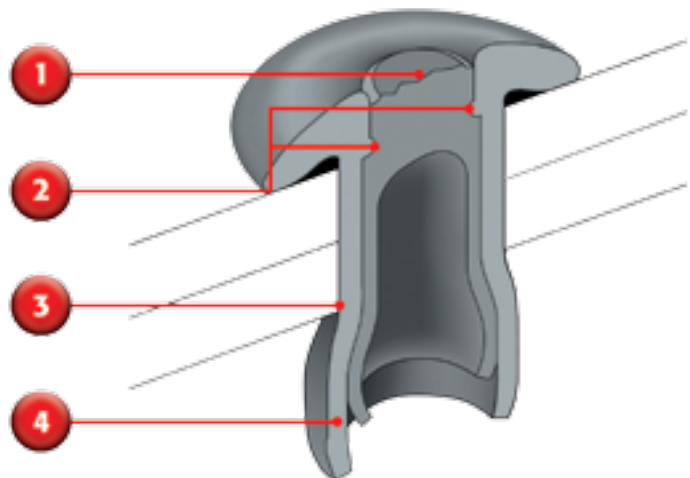

## Installation Sequence

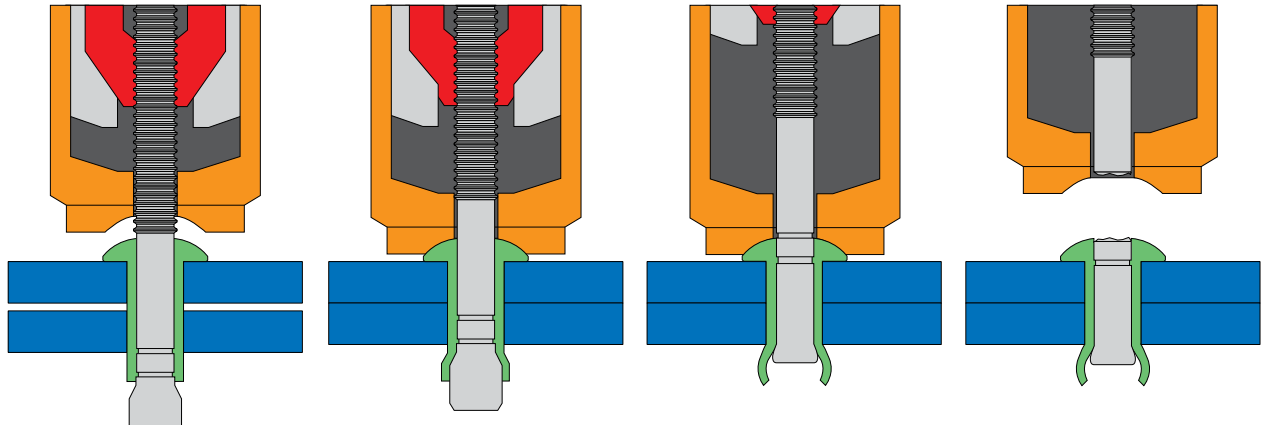

Insert the fastener into the hole and slip the installation tool over the pintail.

Press the trigger to initiate pulling action. As the tool pulls on the pintail, the pin (mandrel) expands the sleeve and begins drawing the work pieces together.

Continued pulling on the pintail draws the hollow pin head inside sleeve. The pin expands inside the sleeve and the work pieces, to completely fill the hole of the work pieces.

A solid circle lock between the pin and sleeve is formed just prior to the pin breaking flush with the sleeve head, completing the installation.



## Magna-Lok Data & Dimensions

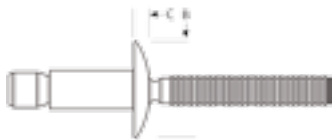

Truss Head

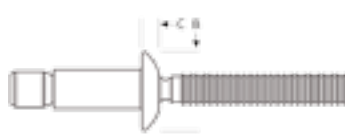

Protruding Head

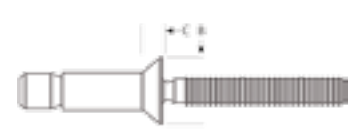

100° Flush Head

### Steel Rivet/Steel Mandrel

Diameter	Part No.	Grip Range	Max Hole Size	[B] Head Dia (max)	[C] Head Height (max)	Typical Shear (lbs)	Typical Tensile (lbs)
<b>Protruding Head</b>							
3/16"	MGLP-R6-4	.062-.270	.201	.392	.101	1450	1200
	MGLP-R6-7	.214-.437	.201	.392	.101	1450	1200
	MGLP-R6-10	.455-.665	.201	.392	.101	1450	1200
	MGLP-R6-E	.062-.437	.201	.392	.101	1450	1200
1/4"	MGLP-R8-6	.080-.375	.272	.530	.120	2750	2200
	MGLP-R8-7	.080-.437	.272	.530	.120	2750	2200
	MGLP-R8-10	.350-.625	.272	.530	.120	2750	2200
	MGLP-R8-14	.580-.875	.272	.530	.120	2750	2200
	MGLP-R8-22	1.080-1.375	.272	.530	.120	2570	2200
	MGLP-R8-E	.080-.625	.272	.530	.120	2750	2200
	MGLP-R8-E 12.6*	.245-.790	.272	.530	.120	2750	2200
3/8"	MGLP-R12-12	.120-.625	.408	.793	.175	6300	5000
1/2"	MGLP-R16-12	.160-.750	.563	1.060	.240	11200	9400
<b>Truss Head</b>							
3/16"	MGLT-R6-4	.062-.270	.201	.530	.104	1450	1200
	MGLT-R6-E	.062-.437	.201	.530	.104	1450	1200
1/4"	MGLT-R8-6	.080-.375	.272	.592	.120	2750	2200
<b>100° Flush Head</b>							
3/16"	MGL100-R6-6	.125-.331	.201	.350	.080	1450	1200
	MGL100-R6-9	.305-.500	.201	.350	.080	1450	1200
1/4"	MGL100-R8-8	.160-.475	.272	.410	.090	2750	2200
	MGL100-R8-12	.415-.725	.272	.410	.090	2750	2200

\* Also available in 400 Stainless Steel

### Aluminum Rivet/Aluminum Mandrel

Diameter	Part No.	Grip Range	Max Hole Size	[B] Head Dia (max)	[C] Head Height (max)	Typical Shear (lbs)	Typical Tensile (lbs)
<b>Protruding Head</b>							
3/16"	MGLP-B6-4	.062-.270	.201	.392	.101	700	580
	MGLP-B6-7	.214-.437	.201	.392	.101	700	580
	MGLP-B6-E	.062-.437	.201	.392	.101	700	580
1/4"	MGLP-B8-6	.080-.375	.272	.530	.120	1300	950
	MGLP-B8-10	.350-.625	.272	.530	.120	1300	950
	MGLP-B8-E	.080-.625	.272	.530	.120	1300	950
3/8"	MGLP-B12-12	.120-.625	.408	.793	.175	3000	2100
1/2"	MGLP-B16-12	.160-.750	.563	1.060	.240	5400	4100
<b>Truss Head</b>							
3/16"	MGLT-B6-4	.062-.270	.201	.530	.104	700	580
	MGLT-B6-7	.214-.437	.201	.530	.104	700	580
	MGLT-B6-E	.062-.437	.201	.530	.104	700	580
<b>100° Flush Head</b>							
3/16"	MGL100-B6-6	.125-.331	.201	.350	.080	700	580
	MGL100-B6-9	.305-.500	.201	.350	.080	700	580
	MGL100-B6-12	.080-.375	.201	.350	.080	700	580
	MGL100-B6-14	.080-.375	.201	.350	.080	700	580
1/4"	MGL100-B8-8	.160-.475	.272	.410	.090	1300	950
	MGL100-B8-12	.415-.725	.272	.410	.090	1300	950

NOTE: Part number listings reflect typical stock. Items not listed require a minimum order.

## Stainless Sleeve/Stainless Mandrel

Diameter	Part No.	Grip Range	Max Hole Size	[B] Head Dia (max)	[C] Head Height (max)	Typical Shear (lbs)	Typical Tensile (lbs)
<b>Protruding Head</b>							
3/16"	MGLP-U6-4	.062-.270	.201	.392	.101	1400	1100
	MGLP-U6-7	.214-.437	.201	.392	.101	1400	1100
	MGLP-U6-E	.062-.437	.201	.392	.101	1400	1100
1/4"	MGLP-U8-6	.080-.375	.272	.530	.120	2500	1800
	MGLP-U8-7	.080-.375	.272	.530	.120	2500	1800
	MGLP-U8-10	.350-.625	.272	.530	.120	2500	1800
	MGLP-U8-E	.080-.625	.272	.530	.120	2500	1800
<b>Flush Head</b>							
3/16"	MGL100-U6-6	.125-.331	.201	.350	.080	1400	1100
	MGL100-U6-9	.305-.500	.201	.350	.080	1400	1100
1/4"	MGL100-U8-8	.160-.475	.272	.410	.090	2500	1800
	MGL100-U8-12	.415-.725	.272	.410	.090	2500	1800

NOTE: Part number listings reflect typical stock. Items not listed require a minimum order.

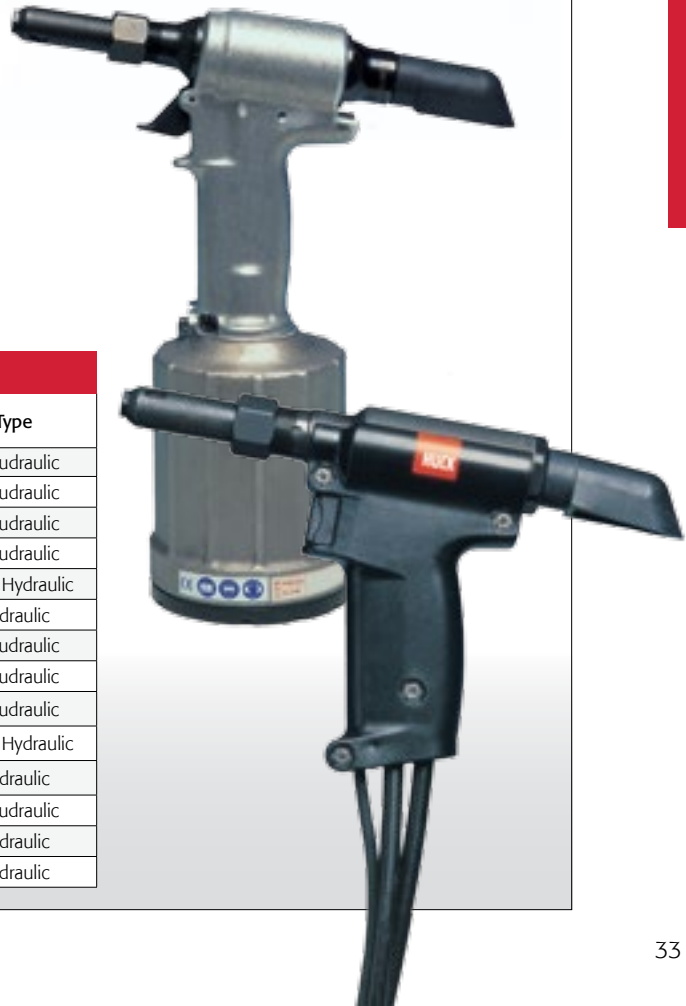

## Installation Tooling

Diameter	Installation Tool	Nose Assembly			Type
3/16"	2025	99-3300	99-3303		Pneudraulic
	2024	99-3303	99-3321-68		Pneudraulic
	2015	125154 (Insert, included with tool)			Pneudraulic
	AK175	120982			Pneudraulic
	HK250	202158			Hand Hydraulic
	2480	99-3300	99-3303	99-3321-68	Hydraulic
1/4"	2025	99-3301	99-3305		Pneudraulic
	2024	99-3301	99-3321-68	99-3305	Pneudraulic
	AK275	202142			Pneudraulic
	HK250	202158			Hand Hydraulic
	2480	99-3301	99-3305	99-3321-68	Hydraulic
3/8"	256	99-3318			Pneudraulic
	2580	99-3318			Hydraulic
1/2"	2503	99-3330	99-3331		Hydraulic



# Magna-Bulb®

A unique bulbing fastener with high shear strength.

Huck Magna-Bulb® is a unique, clamp-type fastener offering high shear strength in specific applications. Its bulbing action during installation spreads the load over more surface area, supplying a stronger, longer-lasting connection, while offering superior blind side strength. This increased bearing area makes Magna-Bulb ideal for pull-out resistance in thin materials, and oversized or misaligned holes. Positive, mechanical pin-retention ensures structural integrity no matter what the application.

#### Available Sizes:

3/16", 1/4", 5/16"

#### Materials:

Steel

#### Headstyles:

Protruding, Truss, 100° Oval Flush

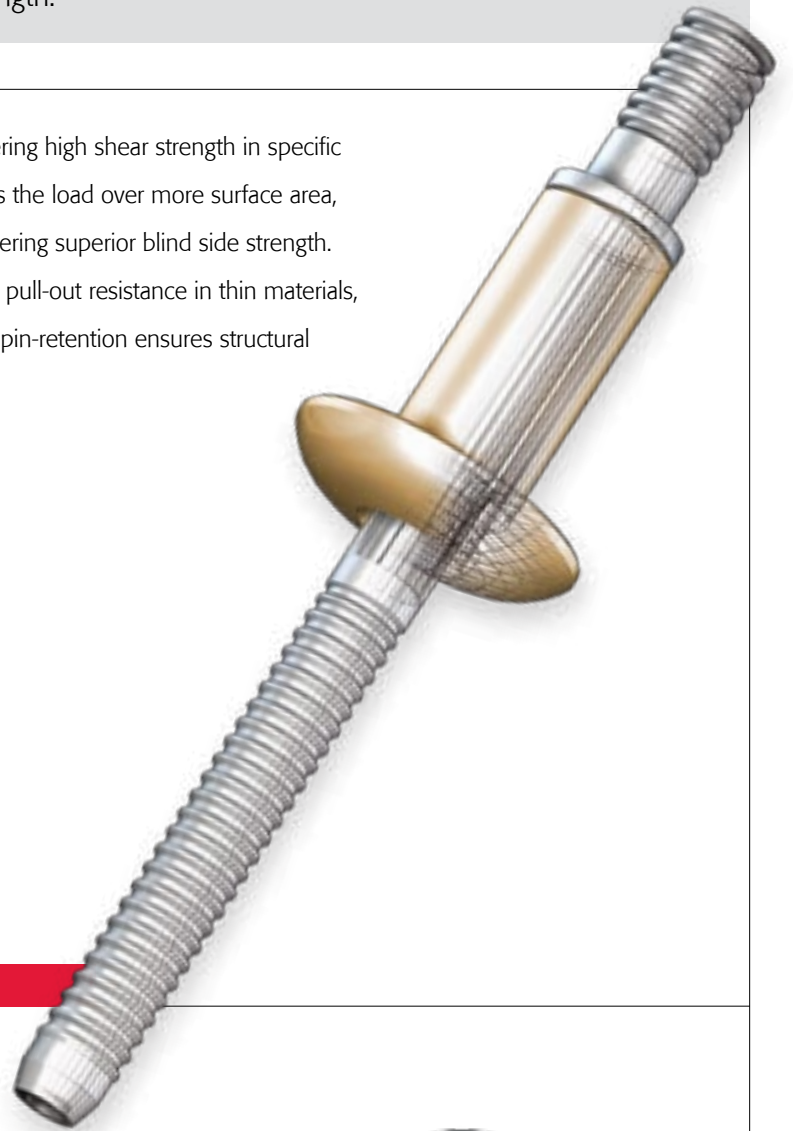

## Secure, Fast Installation

1. Shear ring design promotes bulb formation and grip adjustment for flush break throughout the grip range.
2. The wide blind footprint (bulb) gives the fastener a broader bearing surface, spreading the load out for greater strength and high pull out resistance.
3. Unique solid circle lock ensures maximum strength and resistance to vibration.
4. Breaking flush throughout the entire grip range, the Magna-Bulb fastener eliminates costly cosmetic finish work and ensures "visually" that the fastener has been installed correctly.

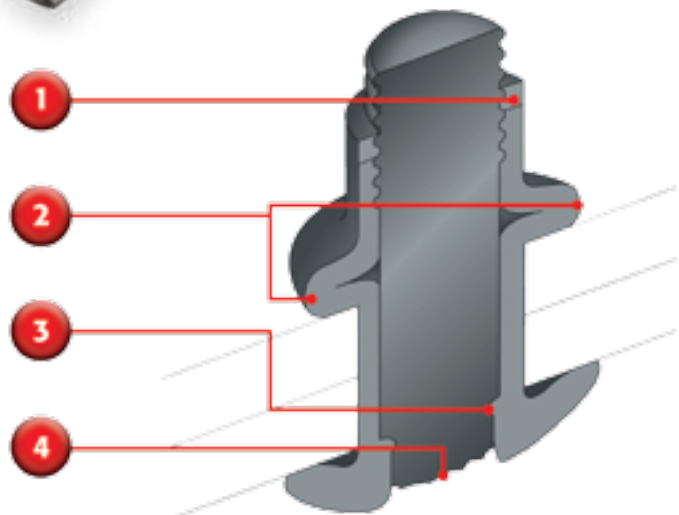



## Installation Sequence

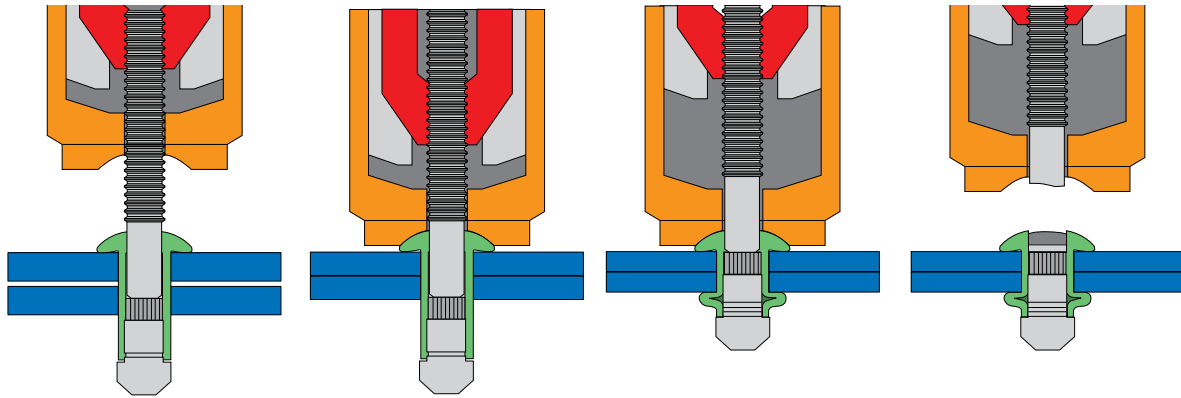

Insert the fastener into the hole and slip the installation tool over the pintail.

Press the trigger to initiate pulling action. As the tool pulls on the pintail, the pin (mandrel) expands the sleeve and begins drawing the work pieces together.

Continued pulling on the pintail expands the bulb to maximum allowable diameter. The shear ring then breaks and catches on the annular grooves as the pin continues to draw down inside the sleeve.

A solid circle lock between the pin and sleeve is formed just prior to the pin breaking flush with the sleeve head, completing the installation.

## Magna-Bulb Data & Dimensions

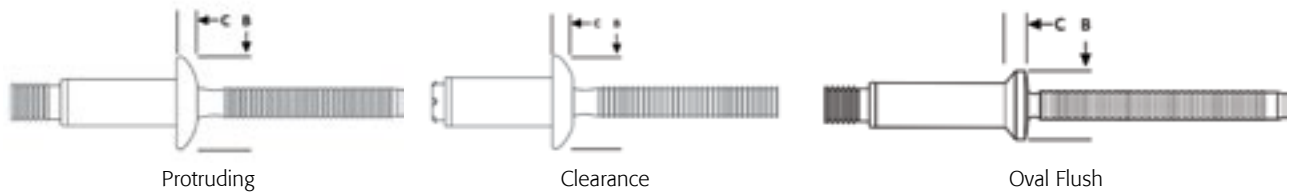

## Steel Rivet/Steel Mandrel

Diameter	Part No.	Grip Range	Max Hole Size	[B] Head Dia (max)	[C] Head Height (max)	Typical Shear (lbs)	Typical Tensile (lbs)
<b>Protruding Head</b>							
3/16"	MBP-R6-M3	.087-.150	.201	.395	.101	1900	1050
	MBP-R6-M4	.126-.189	.201	.395	.101	1900	1050
	MBP-R6-M5	.165-.228	.201	.395	.101	1900	1050
	MBP-R6-M6	.205-.268	.201	.395	.101	1900	1050
	MBP-R6-M7	.244-.307	.201	.395	.101	1900	1050
	MBP-R6-M8	.283-.347	.201	.395	.101	1900	1050
1/4"	MBP-R6-M10	.362-.425	.201	.395	.101	1900	1050
	MBP-R8-M3	.110-.189	.272	.530	.125	2700	2000
	MBP-R8-M4	.150-.229	.272	.530	.125	2760	2000
	MBP-R8-M5	.189-.268	.272	.530	.125	3000	2000
	MBP-R8-M6	.229-.308	.272	.530	.125	3200	2000
	MBP-R8-M7	.268-.346	.272	.530	.125	3600	2000
	MBP-R8-M8	.308-.387	.272	.530	.125	3600	2000
	MBP-R8-M9	.346-.425	.272	.530	.125	3600	2000
	MBP-R8-M10	.387-.466	.272	.530	.125	3600	2000
	MBP-R8-M11	.425-.504	.272	.530	.125	3600	2000
	MBP-R8-M12	.466-.545	.272	.530	.125	3600	2000
	MBP-R8-M13	.504-.583	.272	.530	.125	3600	2000

## Steel Rivet/Steel Mandrel

Diameter	Part No.	Grip Range	Max Hole Size	[B] Head Dia (max)	[C] Head Height (max)	Typical Shear (lbs)	Typical Tensile (lbs)
<b>Protruding Head</b>							
5/16"	MBP-R10-3	.150-.250	.340	.655	.152	5000	3000
	MBP-R10-4	.200-.300	.340	.655	.152	5000	3000
	MBP-R10-5	.250-.350	.340	.655	.152	5000	3000
	MBP-R10-6	.300-.400	.340	.655	.152	5000	3000
	MBP-R10-7	.350-.450	.340	.655	.152	5000	3000
	MBP-R10-8	.400-.500	.340	.655	.152	5000	3000
	MBP-R10-10	.500-.600	.340	.655	.152	5000	3000
<b>Clearance Version*</b>							
1/4"	MBCP-R8-M3	.110-.189	.272	.525	.122	3000	3000
	MBCP-R8-M4	.189-.268	.272	.525	.122	3000	3000
	MBCP-R8-M5	.268-.346	.272	.525	.122	3000	3000
	MBCP-R8-M6	.229-.308	.272	.525	.122	3000	3000
	MBCP-R8-M7	.268-.346	.272	.525	.122	3000	3000
	MBCP-R8-M8	.308-.387	.272	.525	.122	3000	3000
	MBCP-R8-M9	.346-.425	.272	.525	.122	3000	3000
	MBCP-R8-M11	.425-.504	.272	.525	.122	3000	3000
	MBCP-R8-M13	.504-.583	.272	.525	.122	3000	3000
MBCP-R8-M16	.622-.701	.272	.530	.125	3000	3000	

\* MBCP: Please refer to coordination drawings for specifications. NOTE: Part number listings reflect typical stock. Items not listed require a minimum order.

## Installation Tooling

Diameter	Installation Tool	Nose Assembly		Type
3/16"	AK250	-	-	Pneudraulic
	HK250	-	-	Manual
	2015	125154 (Insert, included with tool)		Pneudraulic
	202	99-3303	99-3300	Pneudraulic
	2025	99-3303	99-3303	Pneudraulic
	2480	99-3303	99-3303	Hydraulic
1/4"	AK275	-	-	Pneudraulic
	HK250	-	-	Manual
	2024	99-3301	99-3305	Pneudraulic
	2025	99-3301	99-3305	Pneudraulic
	2480	99-3301	99-3305	Hydraulic
5/16"	256	99-3307	-	Pneudraulic



Wide bulb provides broader bearing surface



# HuckLok®

Wide grip-range and double-locking action for a secure hold.

Featuring a wide grip range and unique double-locking action, the HuckLok® blind rivet combines high shear strength and high pull-up force. Its double-locking action consistently secures the assembly from both sides, resulting in maximum hold and joint integrity. Its large, blind-side footprint prevents pull-through, especially when joining thin or lightweight materials, such as plastics, composites, or any kind of pliable material. Positive mechanical pin retention ensures structural integrity, while annular grooves keep pressure on the back side.

**Available Sizes:**

3/16", 1/4"

**Materials:**

Steel

**Headstyles:**

Protruding, Truss, 100° Oval Flush

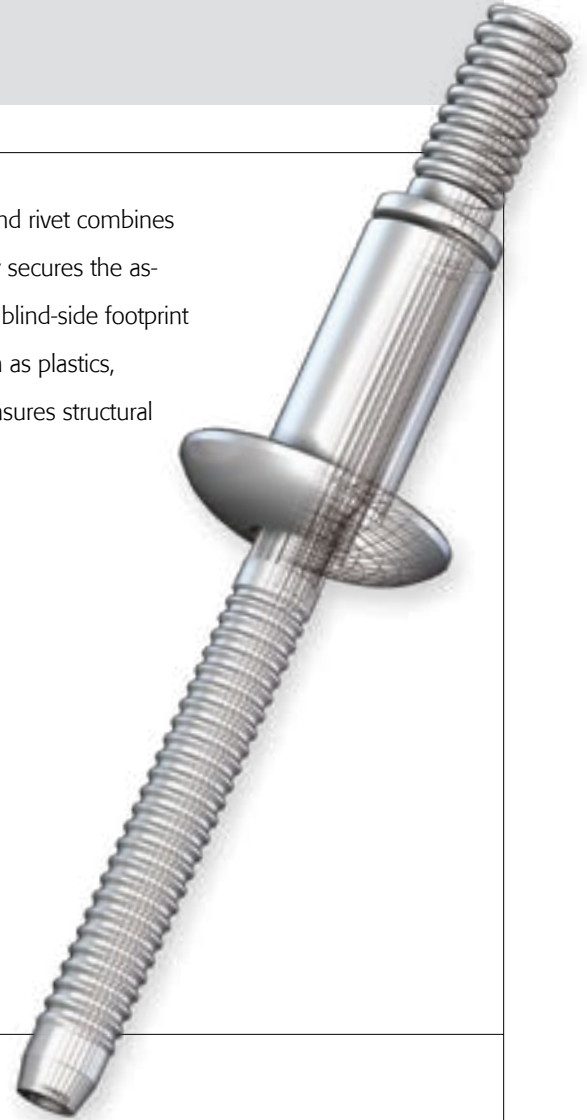

## Secure, Fast Installation

1. Breaking flush throughout its grip range, HuckLok allows at-a-glance verification of installation accuracy.
2. Undercut fillet allows seating in burred holes.
3. Solid pin provides exceptionally high strength in the shear plane.
4. Lock groove on pin engages shoulder on rivet head, while the extruded support ring "double locks" the pin within the bulb.

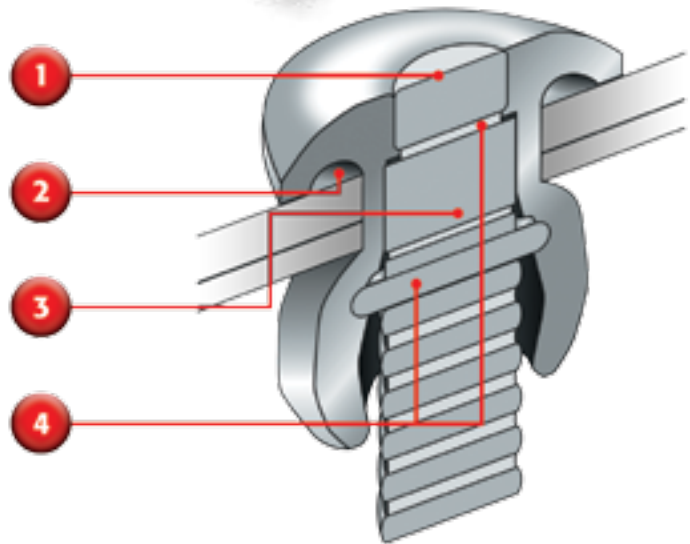

## Installation Sequence

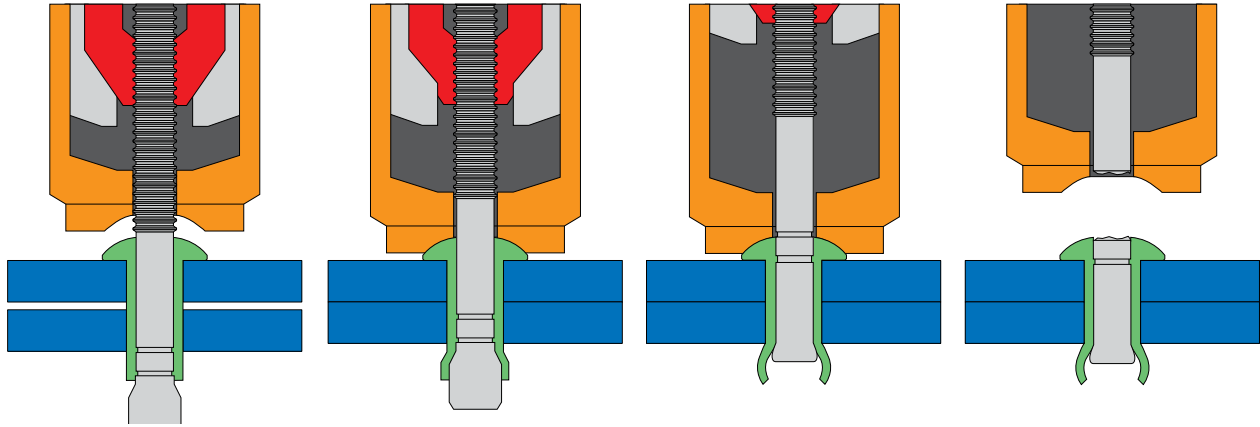

Insert the fastener into the hole and slip the installation tool over the pintail.

Press the trigger to initiate pulling action. As the tool pulls on the pintail, the shear ring feature on the pin pulls inside the sleeve fully expanding the diameter and drawing the work pieces together.

Continued pulling on the pintail expands the sleeve to maximum allowable diameter. As the shear ring reaches the backside of the work piece it breaks and catches on the tapered annular grooves, keeping high pressure on the blind side of the work pieces as the pin continues to draw down inside the sleeve.

A solid circle lock between the pin and sleeve is formed just prior to the pin breaking flush with the sleeve head, completing the installation.

## Huck-Lok Data & Dimensions

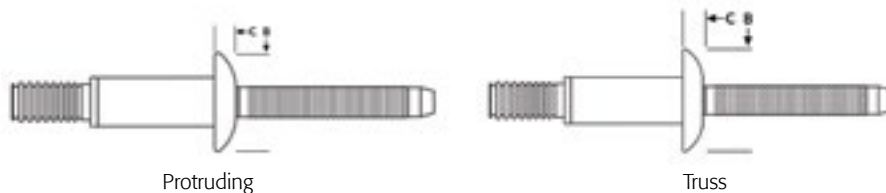

## Steel Rivet - Steel Mandrel

Diameter	Part No.	Finish	Grip Range	Max Hole Size	[B] Head Dia (max)	[C] Head Height (max)	Typical Shear	Minimum Tensile
<b>Protruding Head</b>								
3/16"	HKLP-R6-5	zinc plate clear chromate	.062-.312	.201	.388	.101	1900	1000
	HKLP-R6-5U	zinc plate yellow chromate	.062-.312	.201	.388	.101	1900	1000
	HKLP-R6-5GAT	zinc plate clear chromate plus sealer	.062-.312	.201	.388	.101	1900	1000
1/4"	HKLP-R8-6	zinc plate clear chromate	.080-.375	.272	.530	.125	3500	1900
	HKLP-R8-6U	zinc plate yellow chromate	.080-.375	.272	.530	.125	3500	1900
	HKLP-R8-6S	PVC sealant	.080-.375	.272	.530	.125	3500	1900
	HKLP-R8-7	zinc plate clear chromate	.187-.437	.272	.530	.125	3500	1900
	HKLP-R8-7U	zinc plate yellow chromate	.187-.437	.272	.530	.125	3500	1900
	HKLP-R8-7BL	zinc plate black chromate	.187-.437	.272	.530	.125	3500	1900
	HKLP-R8-7A3	zinc plate clear chromate with glass seal	.187-.437	.272	.530	.125	3500	1900
	HKLP-R8-10	zinc plate clear chromate	.375-.625	.272	.530	.125	3500	1900
	HKLP-R8-10U	zinc plate yellow chromate	.375-.625	.272	.530	.125	3500	1900
	HKLP-R8-12	zinc plate clear chromate	.500-.750	.272	.530	.125	3500	1900
	HKLP-R8-14	zinc plate clear chromate	.625-.875	.272	.530	.125	3500	1900
HKLP-R8-18	zinc plate clear chromate	.875-1.125	.272	.530	.125	3500	1900	
<b>Truss Head</b>								
1/4"	HKLT-R8-6	zinc plate clear chromate	.080-.375	.272	.592	.125	3500	1900

NOTE: Part number listings reflect typical stock. Items not listed require a minimum order.

## Installation Tooling

Diameter	Installation Tool	Nose Assembly				Type
3/16"	202/2022	99-3300	99-3303	99-3304	99-3487	Pneudraulic
	2025	99-3300	99-3303	99-3304	99-3487	Pneudraulic
	202L/2022L/2025L	99-3303L	99-3304L	99-3487L		Pneudraulic
	245/255	99-3327				Pneudraulic
	2480	99-3300	99-3303	99-3304	99-3487	Hydraulic
	2480L		99-3303L	99-3304L	99-3487	Hydraulic
	2480XL			99-3304XL		Hydraulic
1/4"	202/2022	99-3301	99-3305	99-3306	99-3487	Pneudraulic
	2025	99-3301	99-3305	99-3306	99-3487	Pneudraulic
	202L/2022L/2025L		99-3305L	99-3306L	99-3487	Pneudraulic
	245/255	99-3328				Pneudraulic
	2480	99-3301	99-3305	99-3306	99-3487	Hydraulic
	2480L		99-3305L	99-3306L	99-3487	Hydraulic
	2480XL			99-3306XL		Hydraulic
	2480L-2		99-3305-2			Hydraulic



# Auto-Bulb™

A high-strength bulbing fastener available in stainless steel.

For automated, high-speed assemblies, the Huck Auto-Bulb™ is the perfect solution. Unique to the structural blind rivet offering from Huck, Auto-Bulb is available in both steel and 400 stainless steel for ultimate corrosion-resistance.

Auto-Bulb is designed with an easy-to-use lead-in point, which means fast, reliable installation. It works by clamping the joint with a broad, blind side bulb, which makes it a good choice for use within thin materials, and within oversized, misaligned, or slotted holes. Auto-Bulb's positive mechanical pin retention ensures structural integrity, while its unique bulbing system creates superior blind side bearing strength.

**Available Sizes:**

3/16", 1/4"

**Materials:**

Steel, Stainless Steel

**Headstyles:**

Protruding, Flush



## Secure, Fast Installation

1. Tapered hole seeking tip for quick and easy installation.
2. Unique band annealed bulbing system for superior blind side strength.
3. Positive mechanical pin retention ensures structural integrity.

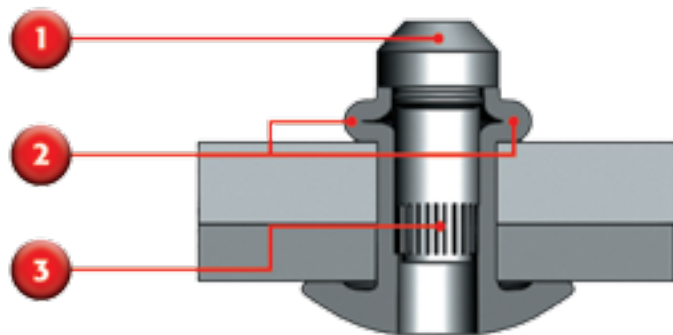



## Installation Sequence

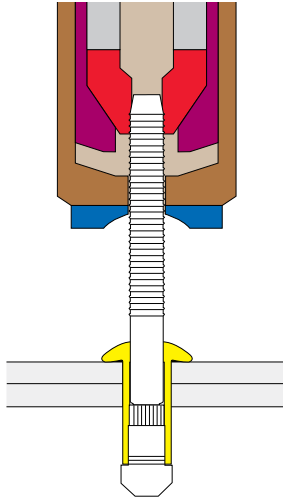

Insert the fastener into the hole and slip the installation tool over the pintail.

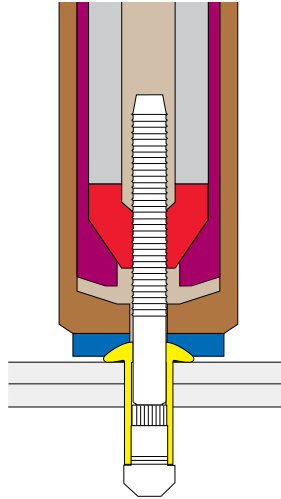

Press the trigger to initiate pulling action. As the tool pulls on the pintail, the solid pin head captures the end of the sleeve and acts to initiate bulb formation and draws the work pieces together.

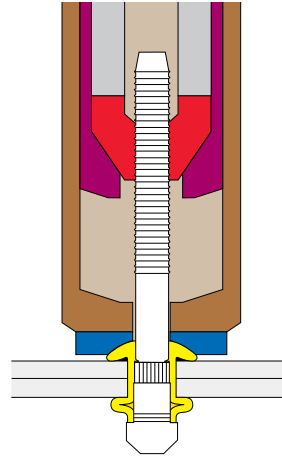

Continued pulling on the pintail expands the bulb to maximum allowable diameter.

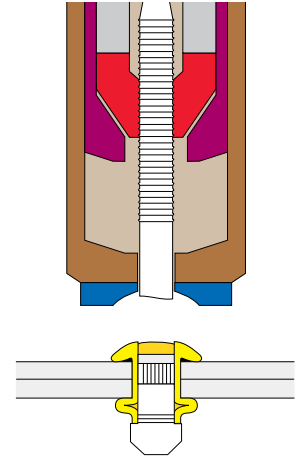

A spline feature on the pin comes into contact with a step on the sleeve creating an interference lock between the pin and sleeve and the pin breaks. The pin will break close to flush in minimum grip and below flush as the grip increases.

## Auto-Bulb Data & Dimensions

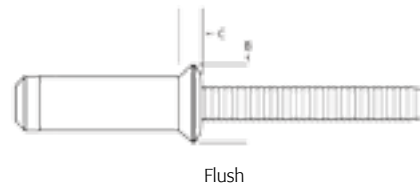
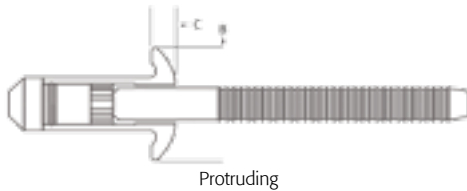

## 430 Stainless Steel

Diameter	Part No.	Grip Range	Max Hole Size	[B] Head Dia (max)	[C] Head Height (max)	Typical Shear (lbs)	Typical Tensile (lbs)
<b>Protruding Head</b>							
1/4"	ABP-4U8-M3	.110-.189	.272	.512	.130	2600	1600
	ABP-4U8-M4	.150-.299	.272	.512	.130	2600	1600
	ABP-4U8-M5	.189-.268	.272	.512	.130	2600	1600
	ABP-4U8-M6	.299-.308	.272	.512	.130	2600	1600
	ABP-4U8-M7	.268-.346	.272	.512	.130	2600	1600
	ABP-4U8-M8	.308-.387	.272	.512	.130	2600	1600
	ABP-4U8-M9	.346-.425	.272	.512	.130	2600	1600
	ABP-4U8-M10	.387-.466	.272	.512	.130	2600	1600
	ABP-4U8-M11	.425-.504	.272	.512	.130	2600	1600
	ABP-4U8-M13	.504-.583	.272	.512	.130	2600	1600

NOTE: Part number listings reflect typical stock. Items not listed require a minimum order.

## Installation Tooling

Diameter	Installation Tool	Nose Assembly	Type
3/16"	2015	125154 (Insert, included with tool)	Pneudraulic
	2024	99-3303	Pneudraulic
	2025	99-3303	Pneudraulic
1/4"	2024	99-3305	Pneudraulic
	2025	99-3305	Pneudraulic



Bulb forms directly on the sheet line

# Magna-Tite®

All-aluminum fastener ideal for thin or low-strength materials.

The Huck Magna-Tite® is a specialized aluminum structural rivet fastener well-suited for use within oversized holes and repair applications. Its wide, blind-side bulb makes it ideal for installation in thin or low-strength materials such as aluminum, fiberglass, and plastic. Unlike other bulbing blind fasteners, the Huck Magna-Tite has a unique embedded sealant applied between the pin and sleeve.

**Available Sizes:**

3/16", 1/4"

**Materials:**

Aluminum

**Headstyles:**

Protruding, Shavable, Low Profile, 100° Oval Flush



## Secure, Fast Installation

1. Large blind-side footprint for installation in thin or compressible materials where controlled strength is required.
2. Unique embedded sealant applied between the pin and sleeve.

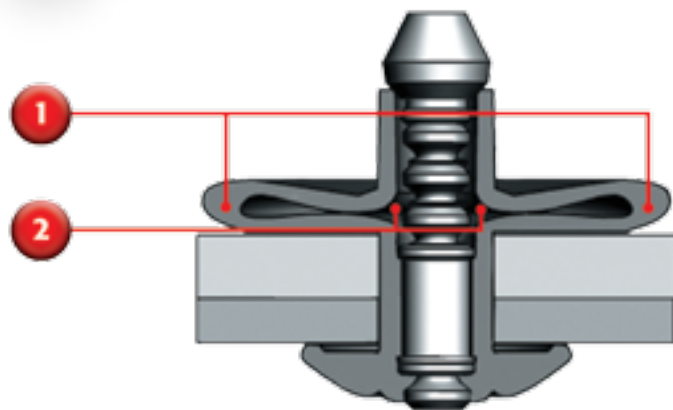

## Magna-Tite Data & Dimensions

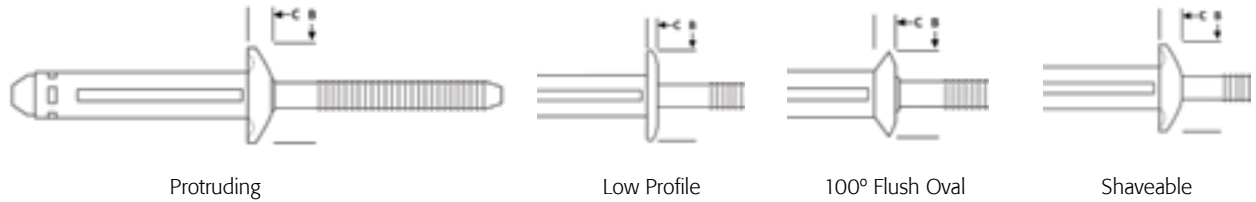

### Aluminum Rivet/Aluminum Mandrel

Diameter	Part No.	Sealant	Grip Range	Max Hole Size	[B] Head Dia (max)	[C] Head Height (max)	Typical Shear (lbs)	Typical Tensile (lbs)
<b>Protruding Head</b>								
3/16"	MTP-B6-5S	PVC	.050-.312	.221	.453	.117	630	450
	MTP-B6-6		.100-.375	.221	.453	.117	630	450
	MTP-B6-6S	PVC	.100-.375	.221	.453	.117	630	450
	MTP-B6-8S	PVC	.250-.500	.221	.453	.117	630	450
	MTP-B6-10S	PVC	.375-.625	.221	.453	.117	630	450
	MTP-B6-12S	PVC	.500-.750	.221	.453	.117	630	450
1/4"	MTP-B8-4		.040-.250	.263	.530	.120	1100	650
	MTP-B8-4S	PVC	.040-.250	.263	.530	.120	1100	650
	MTP-B8-6		.125-.375	.263	.530	.120	1100	650
	MTP-B8-6S	PVC	.125-.375	.263	.530	.120	1100	650
	MTP-B8-8S	PVC	.250-.500	.263	.530	.120	1100	650
	MTP-B8-10S	PVC	.375-.625	.263	.530	.120	1100	650
	MTP-B8-12S	PVC	.500-.750	.263	.530	.120	1100	650
<b>Oval Head</b>								
3/16"	MTV-B6-5S	PVC	.070-.312	.221	.355	.117	630	450
	MTV-B6-7S	PVC	.160-.410	.221	.355	.117	630	450
	MTV-B6-8S	PVC	.250-.500	.221	.355	.117	630	450
	MTV-B6-10S	PVC	.375-.625	.221	.355	.117	630	450
	MTV-B6-12S	PVC	.500-.750	.221	.355	.117	630	450
<b>Low Profile Head</b>								
3/16"	MTLP-B6-4		.050-.250	.221	.453	.052	630*	450
	MTLP-B6-8		.187-.500	.221	.453	.052	630*	450
	MTLP-B6-12		.375-.750	.221	.453	.052	630*	450
	MTLP-B6-12X		.050-.750	.221	.453	.052	630*	450
<b>Shaveable Head</b>								
3/16"	MTS-B6-8		.050-.500	.221	.453	.117	630	450
	MTS-B6-8S	PVC	.050-.500	.221	.453	.117	630	450
	MTS-B6-12S	PVC	.050-.750	.221	.453	.117	630	450

\* In Minimum Grip. 350 lb. shear strength over minimum grip. NOTE: Part number listings reflect typical stock. Items not listed require a minimum order.

### Installation Tooling

Diameter	Installation Tool	Nose Assembly	Type
3/16"	2015	125280 (Insert)	Pneudraulic
	2024	99-3310F/P 99-3311F/P	Pneudraulic
	2480	99-3310F/P 99-3311F/P	Hydraulic
1/4"	2015	125280 (Insert)	Pneudraulic
	2024	99-3312F/P	Pneudraulic
	2480	99-3312F/P	Hydraulic



# BOM®

The highest strength blind oversized fastener available.

Often used as a replacement for welding, Huck BOM® is so strong, one BOM (Blind, Oversized Mechanically locked) fastener can do the work of up to four conventional fasteners. Its unique push-and-pull installation design makes it ideal for military vehicles, auto suspensions, rail car assembly, and much more. BOM's high fatigue thread form extends the life of any structure. Offering accurate, easy, quick installation, BOM requires no special training or skills for operators.

#### Available Sizes:

3/16", 1/4", 5/16", 3/8", 1/2", 5/8", 3/4"

#### Materials:

Steel



## Secure, Fast Installation

1. When the pin separates near flush, the BOM fastener is installed correctly. The BOM fastener does not require surface preparation, grinding or filling after installation.
2. The collar is locked to the pin through the "swaging" process, creating a high vibration resistant connection and the highest strength of any blind fastener.
3. Large bearing area on both sides of the work piece ensures a permanently held, tamper resistant joint.

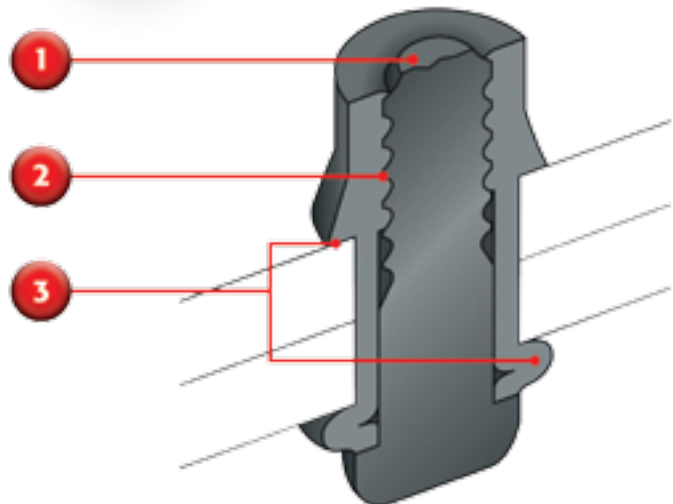

## Installation Sequence

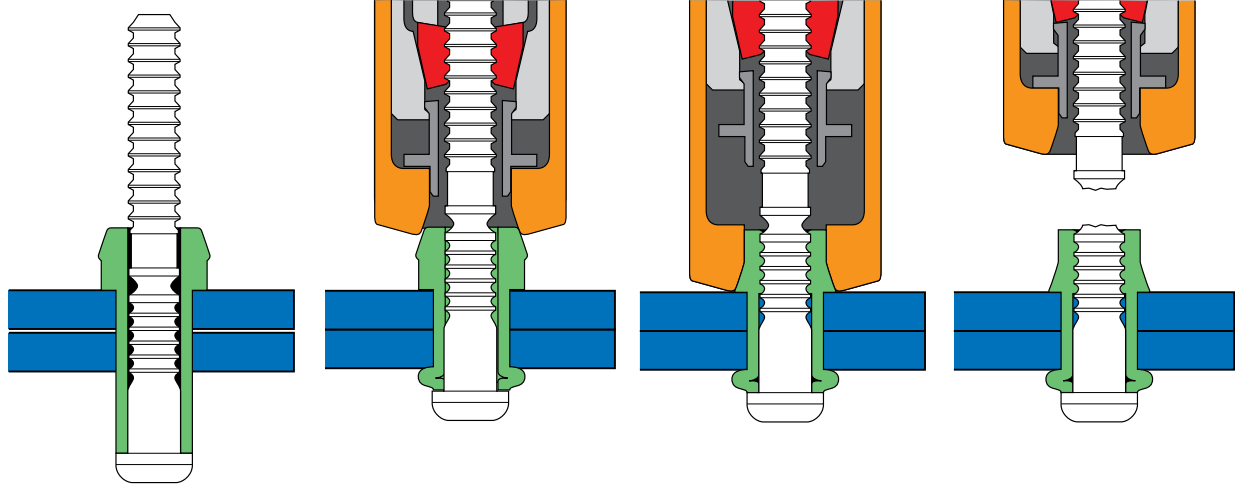

Insert the fastener into the hole and slip the installation tool over the pintail.

Press the trigger to initiate pulling action. As the tool pulls on the pintail, the unique collar design "stands off" the swaging action until the maximum allowable bulb is formed on the backside.

Continued pulling on the pintail draws the work pieces together and the swaging anvil overcomes the standoff and moves down the length of the collar, securely locking the collar to the pin.

Once the collar is swaged, the pin breaks leaving a high strength, vibration resistant secured joint.

## BOM Data & Dimensions

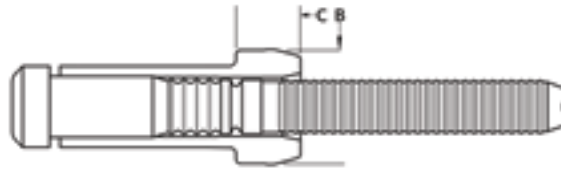

### Steel Pin - Zinc Plated

Diameter	Part No.	Grip Range	Max Hole Size	[B] Head Dia (max)	[C] Head Height (max)	Typical Shear (lbs)	Typical Tensile (lbs)
1/4"	BOM-R8-3	.157-.219	.292	.225	.020	5100	3250
	BOM-R8-4	.220-.281	.292	.225	.020	5100	3250
	BOM-R8-5	.282-.344	.292	.225	.020	5100	3250
	BOM-R8-6	.345-.406	.292	.225	.020	5100	3250
	BOM-R8-7	.407-.469	.292	.225	.020	5100	3250
	BOM-R8-8	.470-.531	.292	.225	.020	5100	3250
	BOM-R8-9	.532-.594	.292	.225	.020	5100	3250
	BOM-R8-10	.595-.656	.292	.225	.020	5100	3250
	BOM-R8-11	.657-.719	.292	.225	.020	5100	3250
5/16"	BOM-R10-4	.188-.312	.368	.278	.025	8050	5200
	BOM-R10-6	.313-.437	.368	.278	.025	8050	5200
	BOM-R10-8	.438-.562	.368	.278	.025	8050	5200
	BOM-R10-10	.563-.687	.368	.278	.025	8050	5200
	BOM-R10-12	.688-.812	.368	.278	.025	8050	5200
	BOM-R10-14	.813-.937	.368	.278	.025	8050	5200

## Steel Pin - Zinc Plated

Diameter	Part No.	Grip Range	Max Hole Size	[B] Head Dia (max)	[C] Head Height (max)	Typical Shear (lbs)	Typical Tensile (lbs)
3/8"	BOM-R12-4	.188-.312	.435	.327	.030	11100	7250
	BOM-R12-6	.313-.437	.435	.327	.030	11100	7250
	BOM-R12-8	.438-.562	.435	.327	.030	11100	7250
	BOM-R12-10	.563-.687	.435	.327	.030	11100	7250
	BOM-R12-12	.688-.812	.435	.327	.030	11100	7250
	BOM-R12-14	.813-.937	.435	.327	.030	11100	7250
1/2"	BOM-R16-10	.626-.750	.581	.458	.035	20150	13000
	BOM-R16-12	.751-.875	.581	.458	.035	20150	13000
5/8"	BOM-R20-4GA	.251-.500	.728	.545	.040	28500	20500
	BOM-R20-8GA	.501-.750	.728	.545	.040	28500	20500
	BOM-R20-12GA	.751-1.000	.728	.545	.040	28500	20500
	BOM-R20-16GA	1.001-1.250	.728	.545	.040	28500	20500
	BOM-R20-20GA	1.251-1.500	.728	.545	.040	28500	20500
3/4"	BOM-R24-4GAG	.251-.500	.873	.654	.050	45100	29100
	BOM-R24-8GAG	.501-.750	.873	1.130	.050	45100	29100
	BOM-R24-12GAG	.751-1.000	.873	1.130	.050	45100	29100
	BOM-R24-16GAG	1.001-1.250	.873	1.130	.050	45100	29100

NOTE: Part number listings reflect typical stock. Items not listed require a minimum order.



## Installation Tooling

Diameter	Installation Tool	Nose Assembly	Type
3/16"	2025	99-994	Pneudraulic
	255	99-1053 (heavy duty)	Pneudraulic
	256	99-1053 (heavy duty)	Pneudraulic
	2480	99-994	Hydraulic
	2580	99-1053 (heavy duty)	Hydraulic
1/4"	255	99-830-1	Pneudraulic
	256	99-830-1	Pneudraulic
	2580	99-830-1	Hydraulic
5/16"	256	99-769	Pneudraulic
	2580	99-769	Hydraulic
	2600	99-3119	Hydraulic
3/8"	2600	99-3122	Hydraulic
	2620	99-5100	Hydraulic
1/2"	2620PT	99-5101	Hydraulic
	2624	99-5102	Hydraulic
5/8"	3585	99-5102	Hydraulic
	3585	99-5103	Hydraulic





# FloorTight®

The only controlled, self-countersinking blind fastener commercially available.

Originally designed for large vehicle flooring installations, Huck FloorTight® is ideal for all wood-to-metal applications, especially plywood and plymetal. FloorTight's self-countersinking head eliminates the secondary counterboring process in plywood, and eliminates dimpling in metals. Unlike screws that can be over-torqued or under-torqued, FloorTight ensures consistent, reliable installation every time.

**Available Sizes:**

1/4", 5/16"

**Materials:**

Steel

**Headstyles:**

Standard, Wide Flange, Plymetal, 90° Flush

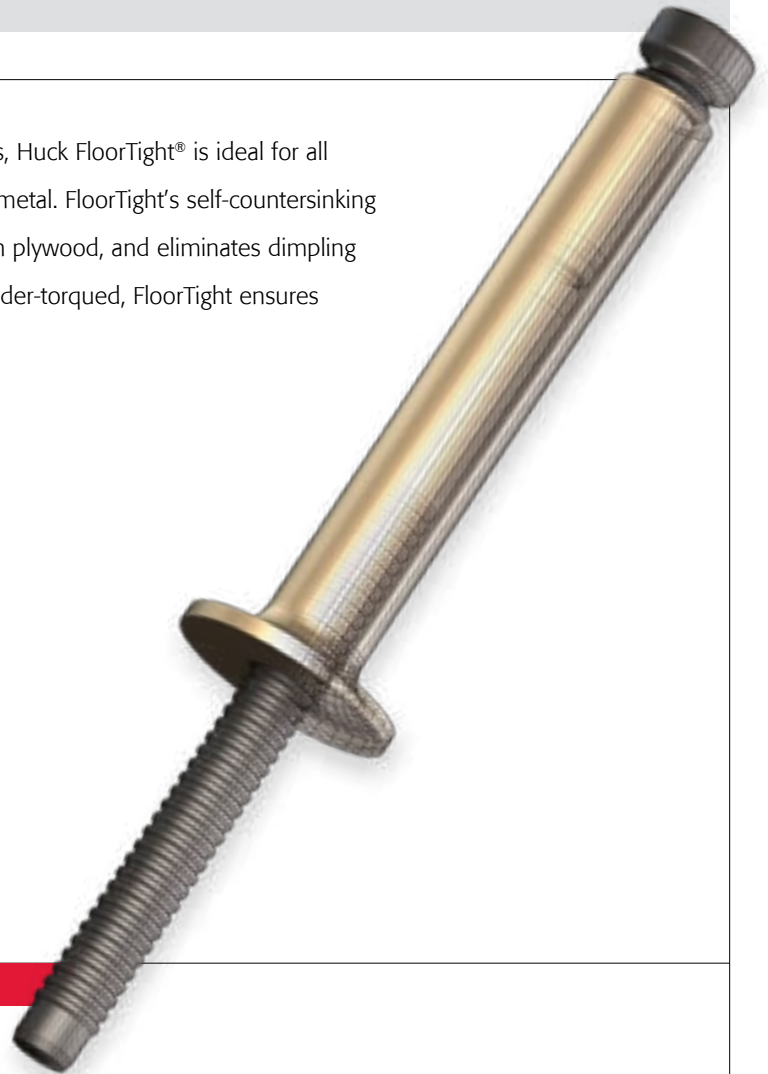

## Secure, Fast Installation

1. Self-countersinking head eliminates the counter-boring process in plywood, as well as dimpling in plymetal floors.
2. A high-strength pin locks in place within the shear plane for added holding power and durability.
3. 360° internal locking feature creates a solid mechanical lock to prevent loosening.
4. Expansion within the weather-side stringer, coupled with the 360° internal lock provides excellent moisture resistance on the weather side.

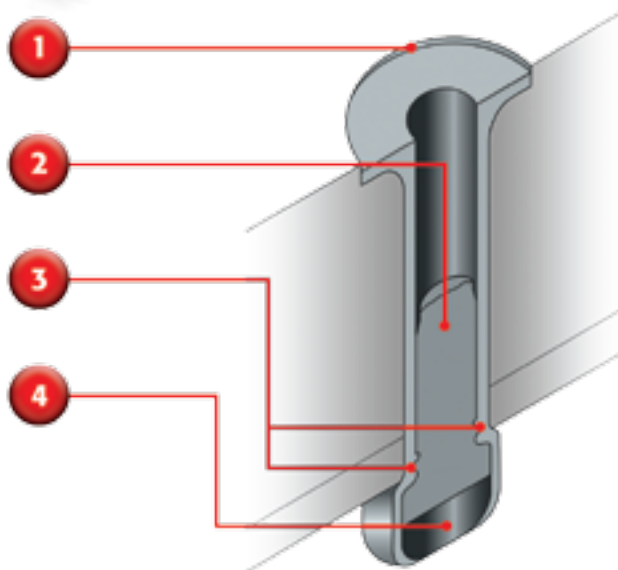

## Installation Sequence

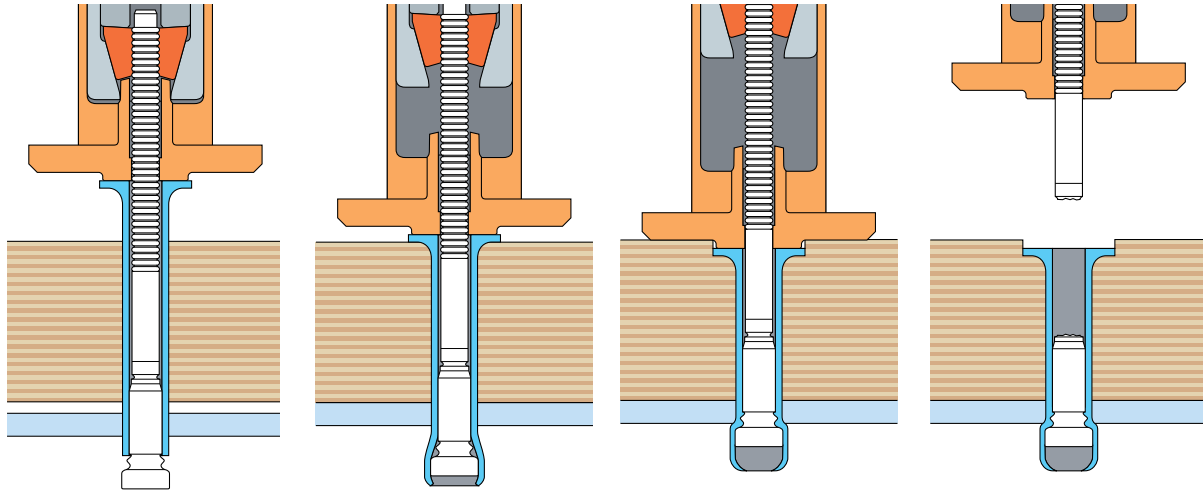

Insert fastener in hole.  
Apply installation tool.

The Huck installation tool is placed over the pintail. When the trigger is pressed, the nose assembly jaws pull on the pintail, drawing the pin through the sleeve, causing the blind side sleeve to expand, partially setting the sleeve in the top sheet and pulling out all the sheet gap.

Continued pulling on the pintail forms a mechanical lock between the pin and sleeve end. The anvil on the installation tool then countersinks the fastener head into the top of the material to a preset depth set by the anvil. The anvil's large bearing face then prevents further travel of the sleeve head into the top material.

The pin is then separated in tension at the break neck groove.

## FloorTight Data & Dimensions

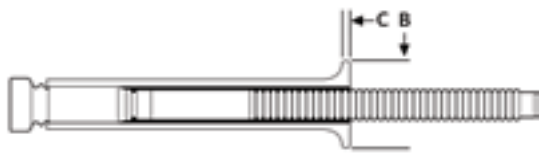

Plywood

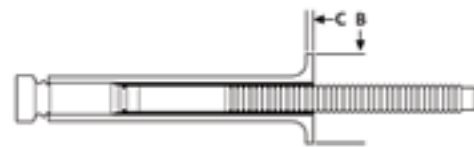

Plymetal

## Steel Sleeves - Steel Mandrel

Diameter	Part No.	Grip Range	Max Hole Size	[B] Head Dia (max)	[C] Head Height (max)	Typical Shear (lbs)	Typical Tensile (lbs)
<b>Plywood Floor</b>							
5/16"	PWF-R10-20	.750-1.375	.339	.325	.650	4300	3000
	PWFMC-R10-20A3	.750-1.375	.339	.675	.050	4300	3000
<b>Plymetal Floor</b>							
5/16"	PMF-R10-20	.750-1.375	.339	.325	.590	4300	3000
	PMFMC-R10-20	.750-1.375	.339	.325	.590	4300	3000

## Installation Tooling

Diameter	Installation Tool	Nose Assembly	Type
1/4"	246	99-3441	Pneudraulic
	2503	99-3441	Hydraulic
5/16"	255	99-3452	Pneudraulic
	256	99-3452	Pneudraulic
	2580/2503	99-3452	Hydraulic



*NOTE: Part number listings reflect typical stock. Items not listed require a minimum order.*

# Huck Tools

The industry's best installation tooling.



Model 507

Designed to offer the highest levels of ergonomics, productivity, and long life, the Huck line of installation tooling reflects the same level of innovation and quality as its advanced fasteners. Whether it's a Huck hydraulic tool employed in high-volume installation of large diameter HuckBolts, or a smaller pneudraulic model used to install blind rivets and small diameter HuckBolts, you can count on these tools to deliver the industry's best value.

## A Wide Selection of Tooling Options

Huck offers a broad selection of hydraulic and pneudraulic tools, and a new battery-powered tool, in addition to Powerig® hydraulic power sources. Huck hydraulic installation tools are available to install a wide range of fasteners, from structural blind rivets to the largest HuckBolts. The Huck line of pneudraulic tools, designed for use in repair work or in lower volume production applications, can effectively pull fasteners ranging from 3/32" blind rivets to 3/8" HuckBolts. The new lightweight, easy to use BT4600 battery-powered tool can install all 3/16" and 1/4" Huck blind rivets (excluding BOM) as well as 3/16" Magna-Grip HuckBolts.



SF20



B4600



256BT



SFBTT8

## Huck Pneudraulic Tooling



### 244BT

The 244BT tool is designed for rapid installation of Huck BobTail 3/16" (5mm) and 1/4" (6mm) diameters. This lightweight tool, featuring a minimal moving parts design, provides for fast, uniform installations, and delivers optimum stroke for one-cycle installation of fasteners.



### 256BT

Designed for quick installation of Huck BobTail fasteners, the 256BT tool features optimum stroke, one-cycle fastener installation, and minimal moving parts. The 256BT includes standard inline nose assemblies, ranging from 5/16" (8mm) to 3/8" (10mm).



### 2022

The Model 2022 is a lightweight, high-speed tool that is well-suited for both production and maintenance/repair applications where 1/4" and smaller diameter (standard and extended grip) blind fasteners are used. The 2022 features a long stroke, in-line piston for production rates of up to 30 installations per minute. The 2022's ergonomically designed handle and light weight (5.4 pounds) combine to minimize operator fatigue.



### 2024

The Model 2024 is designed for production volume installation of 1/4" and smaller diameter blind fasteners. This proven tool offers a number of outstanding features, including an ergonomically designed handle, plated piston rods, and an efficient in-line piston. An extended piston version (2024L) is available and an optional vacuum assist pintail collection system (2024V) can be added.



### 2025

Featuring an ergonomically designed handle, plated piston rods and an efficient in-line piston, the 2025 tool is ideal for high-volume production installation of blind fasteners and two-piece lockbolts, 1/4" and smaller diameter. An extended piston version (2025L) is available and an optional vacuum assist pintail collection system (2025V) can also be added.

## Huck Pneudraulic Tooling



### 254

The Model 254 tool is a high-speed production tool, capable of installing up to 20 fasteners per minute. This lightweight Huck tool is designed for productivity; installing various fasteners from 3/16" (5mm), 1/4" (6mm), 5/16" (8mm), and 3/8" (10mm) blind fasteners and 2-piece lockbolts. The Model 254 provides the stroke required for one-cycle installations, and features a concentric (inline) pull piston and a front gland design that allows for easy piston removal. Factory-tested for 1000 cycles and featuring plated piston rods for extended seal life, the Model 254 is proven durable in a wide range of production applications. The Model 254 weighs only 8.67 pounds, adding to its ergonomics and ease of use.



### 256

The Model 256 tool, designed for high-speed production applications, is able to install up to 20 fasteners per minute. This proven Huck tool is designed to install various fasteners from 3/16" (5mm), 1/4" (6mm), 5/16" (8mm), and 3/8" (10mm) blind fasteners and 2-piece lockbolts, including steel Magna-Grip fasteners. The Model 256 provides optimum stroke for one-cycle installations, and features a concentric (inline) pull piston and front gland design that allows for easy piston removal. The 256 is factory-tested for 1000 cycles, ensuring the tool's reliability, and its plated piston rods extend seal life and adds to its overall durability. This proven production tool weighs only 11.1 pounds.

NOTE: For additional tool details, refer to the specific fastener brochure or visit [AFSRhuck.net](http://AFSRhuck.net).

## Huck Hydraulic Tooling



### SFBTT8

Huck's proprietary Swageforward BobTail® Tool™, the SFBTT, makes the installation process quicker and easier by reducing the force required to install each fastener. The SFBTT8 is designed to install 1/4" (6mm), 5/16" (8mm), and 3/8" (10mm) fasteners.

More compact and lighter weight than previous Huck lockbolt production tooling, all Swageforward BobTail installation tools also offer greater operator flexibility as well as extended reach into difficult areas.

For tight, space-constrained applications, these Huck Swageforward BobTail tools allow the operator to position his or her hand at a safe distance from the working structure during installation.



### SF20

Offering all of the features of the Huck Swageforward BobTail Tool line, the SF20, delivers the power to install 1/2" (12mm), 14 mm, and 5/8" (16mm) BobTail HuckBolts® in high-speed, production environments.



### SF32

The SF32 is Huck's Swageforward BobTail Tool designed for production value installation of 3/4" (20mm) BobTail fasteners.



### SF 46

The heavy duty SF46 Swageforward BobTail Tool is designed to install 7/8" (22mm) – 1" (25mm) BobTail fasteners in a production environment.

## Huck Hydraulic Tooling



### 2480

The Model 2480 is a very lightweight tool which provides for the high-speed installation of a wide range of HuckBolt and Huck blind bolt fasteners. The tool has only one moving part, resulting in outstanding reliability and minimal maintenance. The tight centerline-to-edge measurement of the Model 2480 and its light weight (2.21 pounds) allow for its use in limited clearance areas.



### 2581

Featuring a reliable 2-piece cylinder and handle design, the Model 2581 is a lightweight, high-speed production tool. The 2581's hard plastic handle reduces the weight of the tool, while also ensuring that tool heat is not transferred to the operator. The simple construction of 2581, provides for increased reliability and minimal maintenance.



### 2582/2583

In addition to incorporating many of the features of the 2581, both the Model 2582 and 2583 feature an eccentric piston that allows for an improved center-to-edge measurement for tight clearance applications. The Model 2583 offers a longer stroke, providing for one-cycle installation of a wide range of fasteners, including BobTails.



### 3585/3585PT

Offering durable construction, advanced hydraulics, and a safe, ergonomic design, both the Model 3585 and 3585PT installation tools provide for efficient installation of large diameter HuckBolts. Both of these tools feature an improved piston and cylinder design for longer life. In addition, these tools' nose adapters can be removed through the back of the tool for ease of repair. The Model 3585 is designed to install a wide range of fasteners, including C50LS and BobTail HuckBolts, while the Model 3585PT can efficiently install BobTail, HuckSpin®, and HuckSpin II fasteners.



## Huck Powerig® Power Sources

Combining advanced design and quality manufacturing, Huck Powerigs® offer both best-in-class performance and long product life. Whether for mobile or factory use, there is a Huck Powerig hydraulic power source for the job. Choose from electric- or gasoline-powered portable units or larger rigs that can individually power up to three tools.



### 940

The Model 940 Powerig® is a portable unit sized for moderate production and repair applications. This model features rugged construction for durability in the field, and the choice of 115 or 220 Volt AC power. The Model 940 includes a handle for easy transport, simple adjustable hydraulic outputs, and quick-connect couplers for connecting installation tool hoses.

#### SPECIFICATIONS

Width: 10.5 in.  
Length: 12.5  
Height: 18 in.  
Weight: 74.5 lbs. operational, 66 lbs.  
w/o hydraulic fluid  
Power: electric, 115 or 220 volts,  
single phase  
Flow Rate: 70 cu. in./min. @ 5,000 psi  
Reservoir Capacity: 1.5 gallons  
Options: 220V, 60/50 hertz single  
phase, 250VDC, direct current



### 913F

The Huck Model 913F Powerig® is a portable, gasoline-powered, hydraulic power source designed to operate all Huck hydraulic installation equipment in applications where an air or electric power source is not available. This Powerig hydraulic unit includes a roll cage for protection and to facilitate moving the unit to various work stations. The unit weighs approximately 175 pounds (78.7 kg) when filled with hydraulic fluid.

#### SPECIFICATIONS

Width: 21 in.  
Length: 24 in.  
Height: 27 in.  
Weight: 122 lbs. w/o hydraulic fluid  
Power: gasoline, Honda 5.5hp, 4 cycle,  
single cylinder air- cooled engine,  
point condenser ignition with 3 amp  
charging coil  
Flow Rate:  
Pull 5800 psi, Max 8400 psi  
Return 2800 psi, Max 6000 psi  
Reservoir Capacity: 5 gallons

## Huck Powerig® Power Sources



### 918/918-5

The Model 918 and the 918-5 Powerigs® are the largest hydraulic units offered by Huck. Sized for high production applications, the Model 918 can operate up to two tools independently. The Model 918-5 can power up to three tools. These electrically powered models also deliver sufficient power to operate the tools up to 100 feet away. A 22-gallon reservoir stores hydraulic fluid, with a filter-strainer in the suction line to assure clean, filtered fluid.

#### SPECIFICATIONS

Width: 25 in.  
Length: 44 in.  
Height: 30 in.  
Weight: 780 lbs. operational,  
585 lbs. w/o hydraulic fluid  
Power: electric, 220 or  
440 volts 3 phase  
Flow Rate: 2.0 gpm per tool station  
Reservoir Capacity: 22 gallons

NOTE: For additional tool details, refer to the specific fastener brochure or visit [AFSRhuck.net](http://AFSRhuck.net).









# Arconic Fastening Systems and Rings



Arconic Fastening Systems and Rings, formerly Alcoa Fastening Systems & Rings, is a global leader in fastening technology. Offering the greatest breadth and depth of fastening system solutions in the industry, Arconic continues to reflect the same commitment to product quality and support that customers have come to expect.

To serve its growing market, Arconic Fastening Systems and Rings maintains corporate offices worldwide. In addition, Arconic distributors are located in many key industrial centers throughout the world, providing a ready supply of fasteners, installation tools, tool parts, and application assistance.

## Americas

Waco Operations  
8001 Imperial Drive  
Waco, TX 76712, USA  
P.O. Box 8117  
Waco, TX 76714-8117, USA  
Tel: 800 388 4825  
Fax: 800 798 4825

Kingston Operations  
1 Corporate Drive  
Kingston, NY 12401, USA  
Tel: 800 278 4825  
Fax: 845 334 7333

Tracy Operations  
1925 North MacArthur Drive  
Tracy, CA 95376, USA  
Tel: 800 826 2884  
Fax: 800 573 2645

Carmel Operations  
14300 Clay Terrace Blvd.  
Suite 250  
Carmel, IN 46032, USA  
Tel: 800 826 2884  
Fax: 800 573 2645

Tacubaya Operations  
Avenida Parque Lira  
79-402 Tacubaya  
Mexico C P 11850  
Tel: +52 55 5515 1776  
Fax: +52 55 5277 7564

São Paulo Operations  
Av. Nações Unidas, 12.901  
Torre Oeste, 3º andar  
São Paulo – SP – Brasil  
04578-000  
Tel: 0800 015 9888  
Fax: +55 11 5509 0200

## International Locations

Kolkata Operations  
Unit no. 28, Chowringhee Court  
55/1, Chowringhee Road  
Kolkata – 700071  
India  
Tel: +91 33 4069 9170/80  
Fax: +91 33 4069 9184

Tokyo Operations  
Alcoa Japan Ltd.  
#1013 NBF Hibiya Bldg.  
Uchisaiwai-cho, Chiyoda-ku  
Tokyo 100-1011  
Japan  
Tel: +81 3 3539 6577  
Fax: +81 3 3539 6585

Melbourne Operations  
1508 Centre Road  
Clayton, Victoria, 3168  
Australia  
Tel: +61 3 8545 3333  
Fax: +61 3 8545 3390

Suzhou Fasteners Operations  
58 Yinsheng Road, Shengpu  
Suzhou Industrial Park  
Suzhou Jiangsu 215126  
China  
Tel: 0512 62863800-8888  
Fax: 0512 62863810

Telford Operations  
Unit C, Stafford Park 7  
Telford, Shropshire TF3, 3BQ  
United Kingdom  
Tel: +44 1952 2900 11  
Fax: +44 1952 2904 59

St. Cosme Operations  
9 rue de Cressonnieres  
72110 Saint Cosme en Varais  
France  
Tel: +33 0 2.43.31.41.00  
Fax: +33 0 2.43.31.41.41

Kelkheim Operations  
Industriestr. 6  
65779 Kelkheim  
Germany  
Tel: +49 [0] 6195 8050  
Fax: +49 [0] 6195 2001

[AFSIndustrial.com](http://AFSIndustrial.com)  
[YouTube.com/AFSIndustrial](https://www.youtube.com/AFSIndustrial)

The information contained in this publication is only for general guidance, and is not intended to create any warranty, express, implied, or statutory; all warranties are contained only in AFSR's written quotations, acknowledgments, and/or purchase orders. It is recommended that the user secure specific, up-to-date data and information regarding each application and/or use of such products.

Tangless® is a registered trademark of Advanex Inc.

